



TEREX®

ENVIRONMENTAL EQUIPMENT

TECHNICAL SPECIFICATIONS



TAC Woodsman 700 Brush Chipper Specifications

6" Capacity Towable Disc Chipper, Hydraulic Feed Roll, Top Discharge

SPECIFICATIONS

Operating Weight	1,925 lbs
Chipping Capacity	6"
Gross Engine Power	27 hp
Engine Options	Kohler

FEATURES

24" Diameter x 1 1/4" thick disc with 2 full pockets
6" high by 6" wide chipper opening
Autofeed governor
300 degree swivel discharge

DIMENSIONS

Width	53.5"
Height	94"
Length (Operating)	130"
Length (Transport)	103"

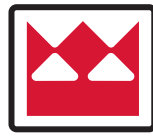

TEREX®

TAC Woodsman 700

ENGINE / DRIVE

- › Make/Model: Kohler Command Pro 27
- › Max hp: 27 hp @ 3,600 rpm
- › Max Torque: 42.3 ft-lb @ 2,400 rpm
- › Fuel: Gasoline
- › Fuel Tank Capacity (gl): 8
- › Oil Capacity (qt): 2
- › Cooling Medium: Air
- › Cylinders: 2
- › Drive: Centrifugal Clutch / Belt

CUTTING SYSTEM

- › Disc Size: 24" dia. x 1.25" width
- › Disc Speed (rpm): 1,567.74 rpm
- › Knives: (2) Double Edged
- › Anvil: 4 edges, 3/4" Steel

FEED SYSTEM

- › Infeed Opening: 6" x 6"
- › Feed Table Height: 33"
- › Feed Table Length: 56"
- › Feed Wheel Diameter: 12.25
- › Feed Wheel Length: 6"
- › Feed Rate (fpm): 150.57
- › Motor Displacement (cu. In.): 18.7 cu. in.
- › Feed Control: 4 Position Bar w/ Autofeed Governor
- › Bar Actuation Force (lbs.): 35
- › Bar Positions: E-Stop, Forward., Stop & Reverse

FEED SAFETY SYSTEM

- › Bottom Feed Stop Bar: 10 Ga. Steel
- › Bar Actuation Force (lbs.): 34
- › Reset Method: Momentary Push Button

DISCHARGE SYSTEM

- › Discharge Height: 94"
- › Chute Rotation: 300°
- › Rotation Type: Manual (Standard Latch)

CHASSIS

- › Frame: 7 Ga. Steel
- › Hitch Type: 2" Ball Coupler
- › Tool Box: Yes
- › Wheels: 8" x 7" - 5 bolt hub
- › Tires: 20.5 x 8
- › Axle: 2,000 lb torsion axle

HYDRAULIC

- › System: Open Center
- › Hydraulic Tank Capacity (gl): 8
- › Filtration: 10 Micron
- › Pump (gpm): 3.8
- › System Relief (psi): 2,500

ELECTRICAL

- › System Voltage: 12V
- › Battery: 12V 800 CCA
- › Lights: Turning, license, brake, tail and side marker

WEIGHTS

- › Tongue Weight (lbs.):
- › Operating Weight (lbs.): 1,925

DIMENSIONS

- › Width: 53.5"
- › Height: 94"
- › Length: 130"
- › Transport Length: 103"

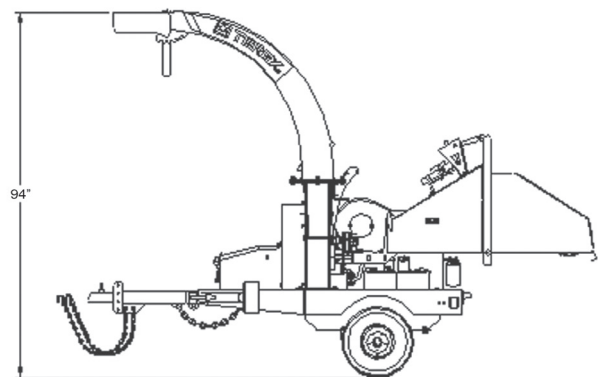
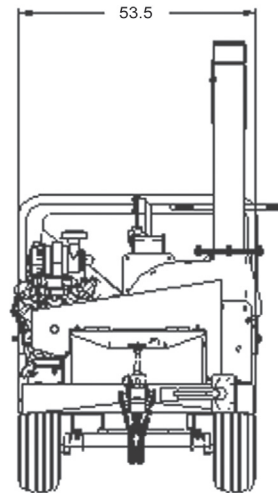
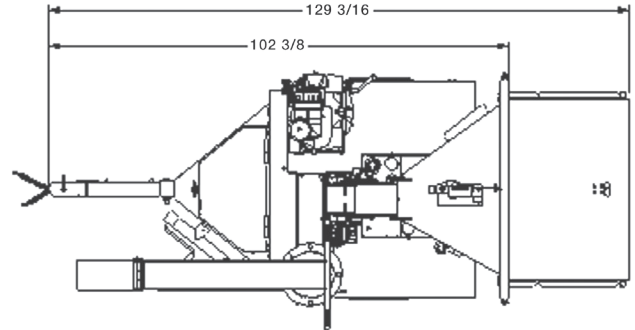

www.terex.com/environmental-equipment

Product specifications and prices are subject to change without notice or obligation. The photographs and/or drawings in this document are for illustrative purposes only. Refer to the appropriate Operator's Manual for instructions on the proper use of this equipment. Failure to follow the appropriate Operator's Manual when using our equipment or to otherwise act irresponsibly may result in serious injury or death. The only warranty applicable to our equipment is the standard written warranty applicable to the particular product and sale and Terex makes no other warranty, express or implied. Products and services listed may be trademarks, service marks or trade-names of Terex Corporation and/or its subsidiaries in the USA and other countries. All rights are reserved. Terex is a registered trademark of Terex Corporation in the USA and many other countries.

© 2011 Terex Corporation.
Terex Woodsman - 1250 Commerce Drive - Farwell, MI 48622 USA
Tel +1 (989) 588-4295 - salesenvironmental@terex.com

WORKS FOR YOU.™