

MATERIAL HANDLER

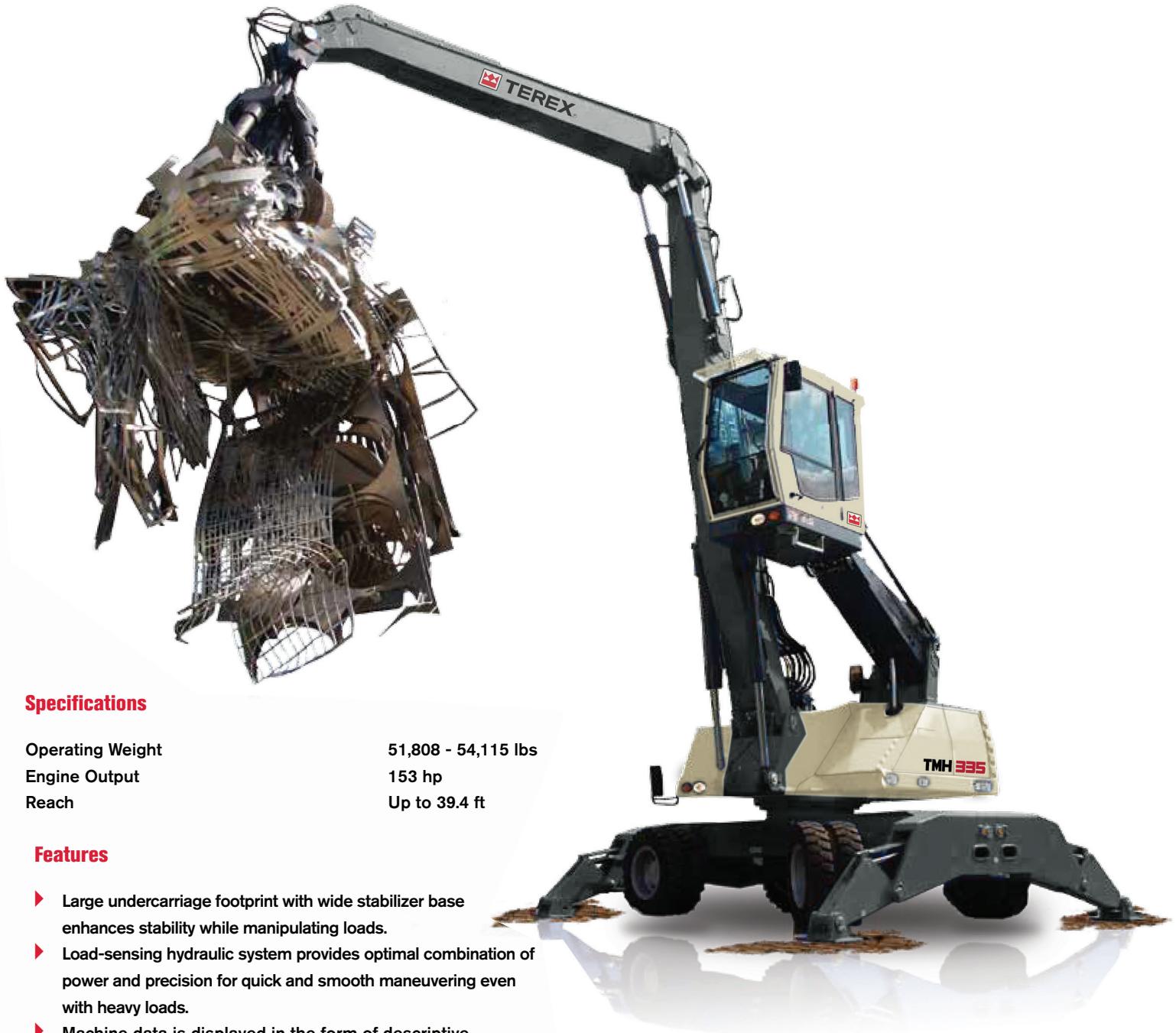

Specifications

Operating Weight	51,808 - 54,115 lbs
Engine Output	153 hp
Reach	Up to 39.4 ft

Features

- ▶ Large undercarriage footprint with wide stabilizer base enhances stability while manipulating loads.
- ▶ Load-sensing hydraulic system provides optimal combination of power and precision for quick and smooth maneuvering even with heavy loads.
- ▶ Machine data is displayed in the form of descriptive symbols and text on the easily accessible multi-function color monitor.

WORKS FOR YOU.[™]

SPECIFICATIONS

ENGINE

Manufacturer, Model	Deutz TCD 2012 L06 2V
Design	6 Cylinder Inline
Engine Control	EMR III
Type	4-stroke Diesel engine, direct common-rail fuel-injection, turbocharger with charge air cooling
Engine Output	153 hp
Nominal Speed	2000 rpm
Displacement	366 in ³
Cooling System	Liquid intercooling with temperature controlled fan speed
Emission Standards	TIER III and COM III
Air Filter Design	Two-stage filter with safety valve
Fuel Tank Capacity	80 gal

ELECTRICAL SYSTEM

Operating Voltage	24 V
Batteries	2 x 12 V / 100 Ah / 760 A (in accordance with EN)
Lighting Set	Dipperstick-mounted floodlight, Headlight mounted to uppercarriage, Floodlight attached to cab floor Rear side-marker Turn signal lamps
Generator	13kW generator with control, driven by v-belt direct from diesel engine

TRAVEL DRIVE

Hydrostatic drive through infinitely variable axial piston motor and directly mounted travel brake valves, two-speed power shift gear, 4-wheel drive	
Max Travel Speed	1 st gear 3.1 mph 2 nd gear 12.4 mph
Gradeability	maximum 45%
Turning Radius	26.9 ft

SWING SYSTEM

Ring Gear	Internally toothed ball ring gear (double row)
Drive	Two-stage planetary gear with integrated multi-disc brake
Upper Carriage Swing Speed	Infinitely variable from 0 - 8 rpm
Pivot Brake	Electrically operated

UNDERCARRIAGE

Front Axle	Planetary drive axle with integrated drum brake, rigidly mounted max steering angle 27°
Rear Axle	Oscillating planetary drive rear axle with integrated drum brake and selectable oscillating axle lock
Tires	Solid rubber, elastic tires 8-fold 10.00 - 20
Stabilizers	4-point stabilizers



BRAKE SYSTEM

Service Brake	Hydraulic single circuit braking system acting on all four wheel pairs
Parking Brake	Electrically operated disc brake at transmission, acting on both axles

HYDRAULIC SYSTEM

REXROTH mobile hydraulic system with load limit control and fuel conserving power demand control fan speed, Separate oil cooler, temperature-regulated fan speed. Hydraulic oil filter: Filter elements integrated in the oil tank; maintenance interval up to 3,000 operating hours. Central lubrication system	
Maximum Pump Capacity	100.3 gal/min
Maximum Operating Pressure	4641/5221 psi
Hydraulic Oil Tank	90 gal

OPERATOR'S CAB

Elastically supported, infinitely variable hydraulically height-adjustable with max eye level of 17.4 ft (5.3 m). Sound-deadened, heat-insulated panoramic windows for optimum all-around view, windshield with pull-down sun blind that slides under cab roof, sliding window in cab door, steering column height and tilt adjustable.	
Heating	Infinitely variable hot water heating adjustable defroster nozzles
Operator's Seat: Air-cushioned comfort seat with integrated headrest, safety belt and lumbar support, seat heating with integrated A/C function optional. Seat position, seat inclination and seat cushion multi-adjustable in line with position of armrests and pilot control units, allowing comfortable operation	
Monitoring Ergonomic, glare-free instrument layout, multi-function display; automatic monitoring; warning and storage of deviating operating conditions, e.g. filter pressure monitoring with warning indicator or shutdown of pilot controls, warning or shutdown of pilot controls when exceeding maximum hydraulic fluid temperature	
Air conditioning	Automatic
Sound power level	$L_{WA} = 102\text{dB(A)}$ (Guaranteed) in accordance with guideline 2000/14 EG

SAFETY INSTALLATIONS

For crane operations in accordance with EN 474-5.
Cab protection by close proximity range limiter.

OFFICIAL HOMOLOGATION

Certification in accordance with CE regulations.
--



EQUIPMENT

TMH335

ENGINE SERIES OPTION

Turbocharger	•
Intercooling	•
Direct electronic fuel injection/ Common Rail	•
Automatic idle	•
Interface for engine diagnosis	•
Temperature-controlled fan drive	•

UNDERCARRIAGE SERIES OPTION

2-speed power-shift transmission	•
4-point stabilizers	•
4-point stabilizers, individually controllable	•
Stabilizer cylinders with integrated two-way check valves	•
All-wheel drive	•
Piston rod protection on stabilizer cylinders	•
Stabilizer plates 19.7 x 13.8 in	•
Rear axle oscillating lock	•
Blade in addition to 4-point stabilizers	•
Special paint	•
Drum brakes	•
Toolbox	•

UPPERCARRIAGE SERIES OPTION

Electric refuelling pump	•
Lighting protection	•
Maintenance hood, actuated by gas strut, with mechanical locking device	•
Lockable cleaning access openings on radiator	•
Separate radiator system for ambient temperatures up to 122° F (50° C)	•
Separate oil cooler with temperature controlled fan drive	•
Back-up alarm	•
Special paint	•
Quick drain valve on diesel tank (delivered in tool box)	•
Quick drain valve on hydraulic oil tank	•
Quick drain valve on water cooler	•
Quick drain valve on engine oil pan	•
Reversible fan for engine and hydraulic oil cooler	•
Automatic central lubrication system	•

CAB SERIES OPTION

Lift-up skylight in cabin roof	•
Air cushioned operator's seat with headrest, safety belt and lumbar support	•
FOPS protective cab guard	•
Hinged front windshield	•
Front windows, break-resistant (LEXAN)	•
Bullet-proof glass, front and top	•
Cab system, height adjustable	•
Air-conditioning	•
Steering column, height and tilt adjustable	•
Multi-functional color display	•
Fire extinguisher, dry powder	•
Radio and CD player	•
Flashing beacon	•
Sliding window in cab door	•
Safety glass	•
Seat heating	•
Windshield washer system	•

EQUIPMENT SERIES OPTION

Working floodlight on cab floor	•
Working floodlights on uppercarriage	•
Working floodlight on dipperstick, left	•
Close proximity range limiter for dipperstick	•
Coolant and hydraulic oil level monitoring system	•
Load holding protection for boom cylinders	•
Load holding protection for stick cylinders	•
Dipperstick shock protection	•
Lubrication of the grab suspension through the central lubrication system	•
Overload warning / shut-off installation	•
XENON floodlight on dipperstick	•
XENON floodlight on uppercarriage	•
XENON floodlight on cab roof	•
Quick attach coupling on dipperstick	•

WORKS FOR YOU.™

GENERAL DIMENSIONS

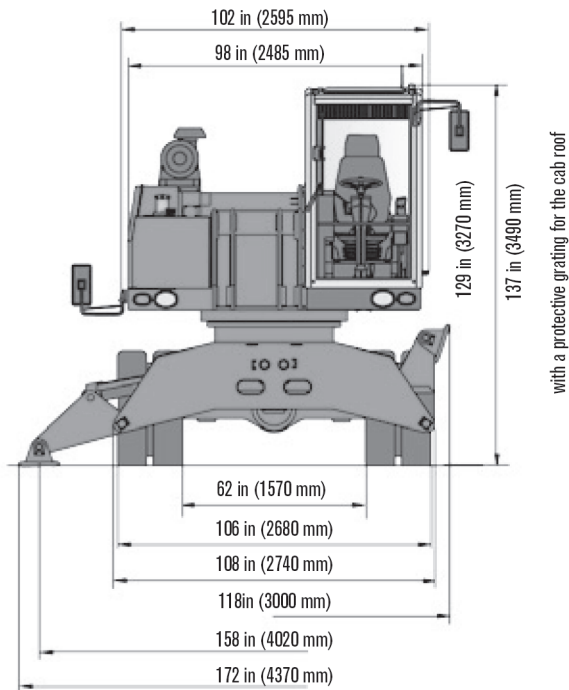
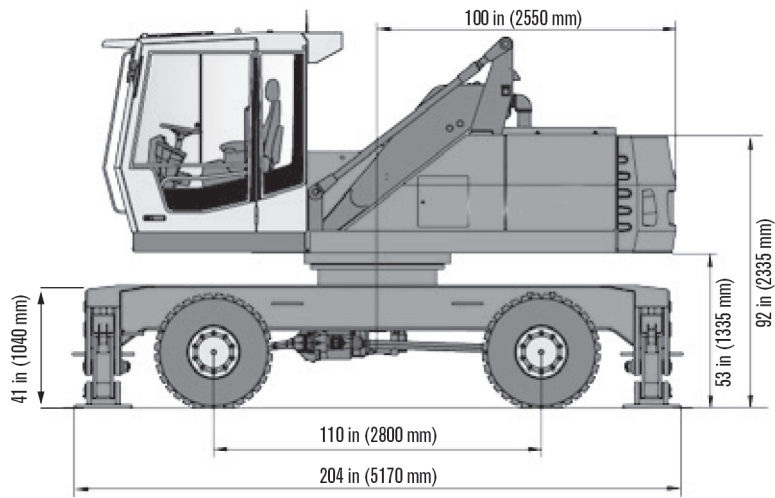

TRANSPORT DIMENSIONS

TMH335

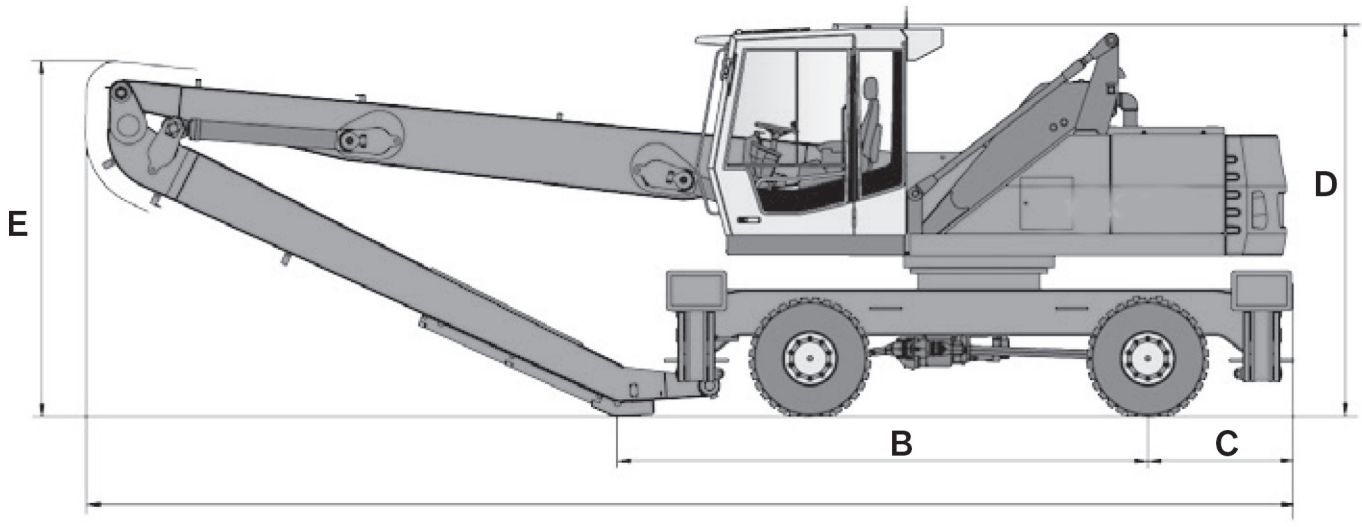

Dimensions	Reach 39.4 ft (12 m)	Reach 36 ft (11 m)	Reach 35 ft (10.7 m) (Multi-Purpose Stick)
A	394 in (10000 mm)	394 in (10000 mm)	398 in (10100 mm)
B	173 in (4400 mm)	217 in (5500 mm)	211 in (5350 mm)
C	47 in (1185 mm)	47 in (1185 mm)	47 in (1185 mm)
D	129 in (3270 mm) 137 in (3490 mm)*	129 in (3270 mm) 137 in (3490 mm)*	129 in (3270 mm) 137 in (3490 mm)*
E	118 in (3000 mm)	106 in (2700 mm)	109 in (2780 mm)

* with protective grating for cab roof

WORKS FOR YOU.™

WORKING RANGES

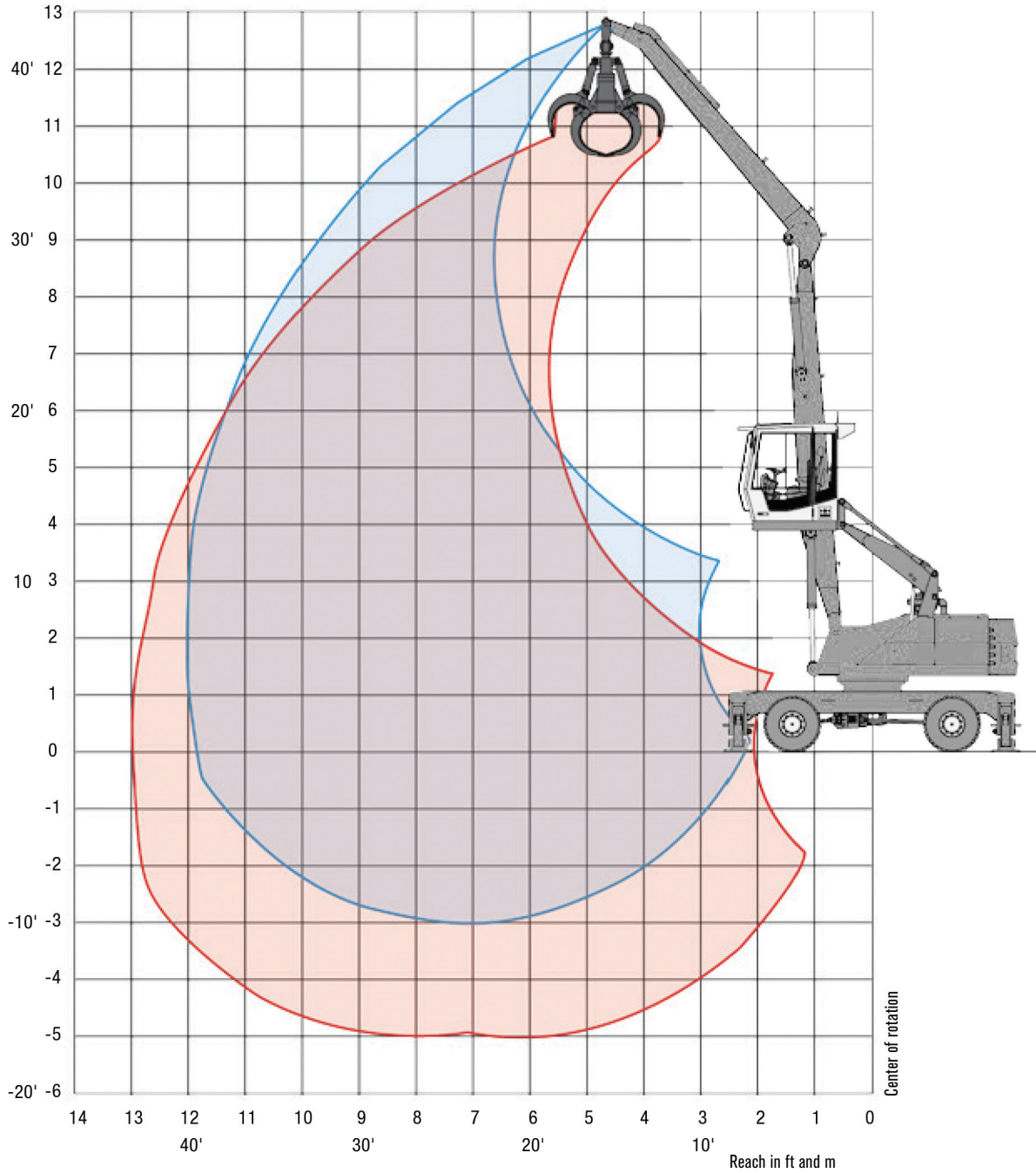

Reach 39.4 ft

Work equipment:
Box-type boom 21.3 ft
Stick 17.9 ft

LIFTING CAPACITIES

TMH335

HEIGHT ft	UNDERCARRIAGE STABILIZERS	REACH ft					
		15	20	25	30	35	40
35	non supported			(9,750*)			
	4-pt. supported			9,750* (9,750*)			
30	non supported			(10,070)	(7,420)		
	4-pt. supported			11,330* (11,330*)	9,110* (9,110*)		
25	non supported			(10,030)	(7,440)	(5,690)	
	4-pt. supported			11,360* (11,360*)	10,770* (10,770*)	7,100* (7,100*)	
20	non supported			(9,820)	(7,330)	(5,670)	
	4-pt. supported			11,930* (11,930*)	11,040* (11,040*)	8,720 (9,840*)	
15	non supported		(13,400)	(9,470)	(7,130)	(5,560)	
	4-pt. supported		14,800* (14,800*)	12,930* (12,930*)	10,960 (11,580*)	8,620 (10,570*)	
10	non supported	(19,560)	(12,580)	(9,020)	(6,870)	(5,420)	(4,390)
	4-pt. supported	22,400* (22,400*)	17,140* (17,140*)	14,100* (14,190*)	10,680 (12,270*)	8,460 (10,490)	6,400* (6,400*)
5	non supported	(17,750)	(11,730)	(8,560)	(6,600)	(5,270)	(4,330)
	4-pt. supported	27,150* (27,150*)	19,110 (19,450*)	13,590 (15,430*)	10,390 (12,940*)	8,300 (10,330)	6,850* (6,870*)
0	non supported	(16,570)	(11,070)	(8,180)	(6,370)	(5,150)	
	4-pt. supported	19,980* (19,980*)	18,360 (21,000*)	13,170 (16,300*)	10,140 (12,720)	8,170 (10,190)	
-5	non supported	(16,080)	(10,700)	(7,930)	(6,220)	(5,080)	
	4-pt. supported	16,440* (16,440*)	17,930 (21,340*)	12,890 (16,410*)	9,980 (12,550)	8,090 (10,110)	
-10	non supported			(7,840)			
	4-pt. supported			12,790 (15,770*)			

RECOMMENDED ATTACHMENTS*

Lift Hook	22046 lbs
Terex® Cactus Grab	0.52 yd ³ open or half-closed tines
Terex® Cactus Grab	0.78 yd ³ open or half-closed tines
Clamshell Grab	0.85 yd ³ density to 2360 lbs/yd ³
Clamshell Grab	1.3 yd ³ density to 1348 lbs/yd ³
Terex® Magnet Plate MP 1250	diameter = 49 in with 13 kW magnet system

* May vary depending on material being handled and operating conditions.

Capacity values are stated in lbs. The pump pressure is 5,221 psi (360 bar). The values, in accordance with ISO 10567, amount to 75% of the static tipping load or 87% of the hydraulic lifting force (marked *). They apply to slewing operations through 360° on a firm and level surface.

Values in parentheses apply to the longitudinal direction of the undercarriage. "Non-supported" values apply when the load is hoisted above the front or rear axle.

The weight of the attached hoisting equipment (grab, magnet, coupler, lift hook, etc.) must be deducted from the capacity values. Load holding valves on the lift cylinders and an overload warning device are required for crane operations.

WORKS FOR YOU.™

WORKING RANGES

Reach 36 ft

Work equipment:

Box-type boom 21.3 ft (6.5 m)

Stick 14.4 ft (4.4 m)

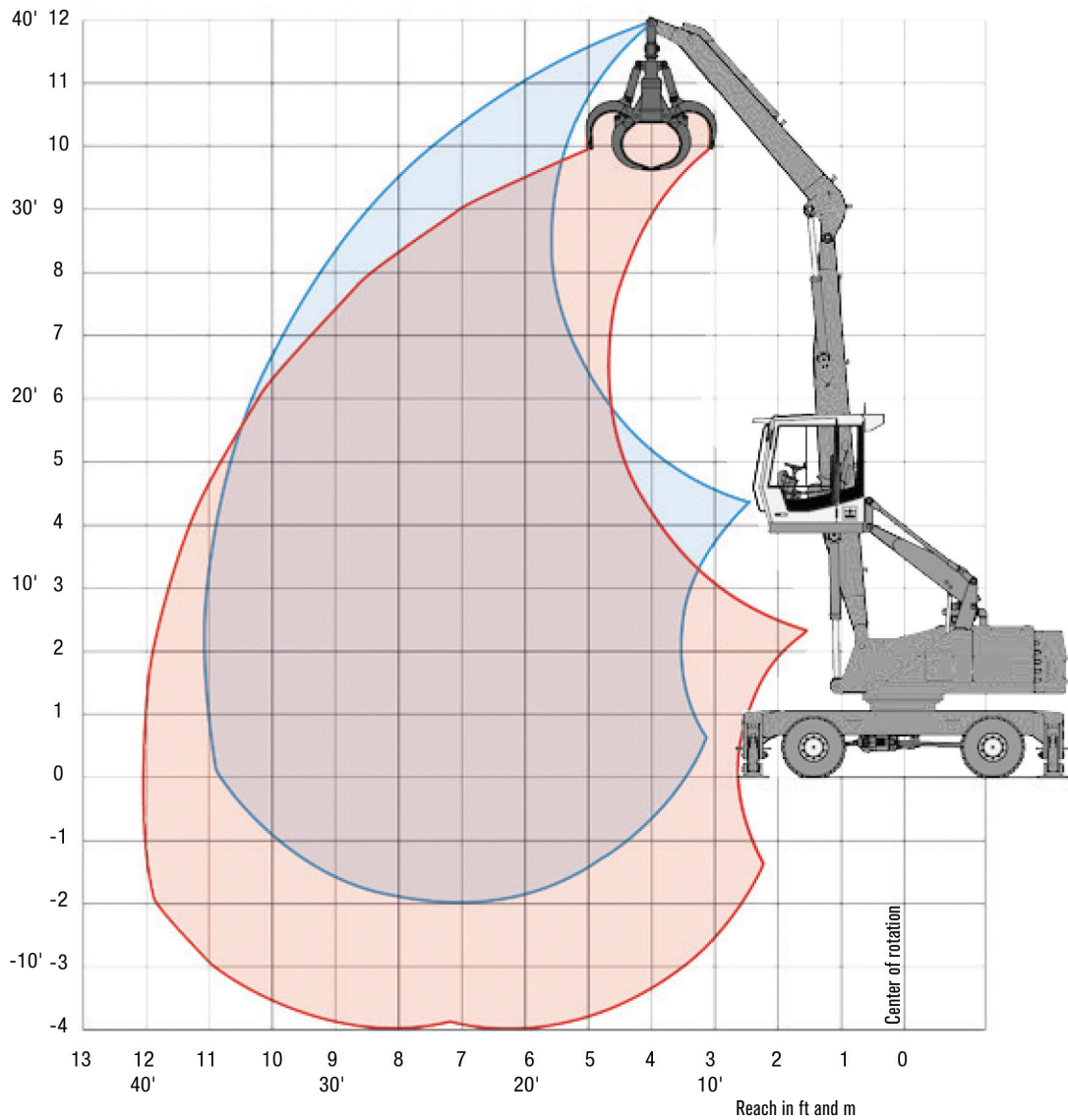

LIFTING CAPACITIES

TMH335

HEIGHT ft	UNDERCARRIAGE STABILIZERS	REACH ft				
		15	20	25	30	35
35	non supported		(12,640*)			
	4-pt. supported		12,640* (12,640*)			
30	non supported		(13,910)	(9,710)		
	4-pt. supported		14,050* (14,050*)	12,580* (12,580*)		
25	non supported		(13,830)	(9,710)	(7,210)	
	4-pt. supported		14,160* (14,160*)	12,900* (12,900*)	11,040 (11,120*)	
20	non supported		(13,470)	(9,520)	(7,150)	
	4-pt. supported		15,170* (15,170*)	13,390* (13,390*)	10,970 (12,140*)	
15	non supported	(20,120)	(12,860)	(9,200)	(6,980)	(5,490)
	4-pt. supported	21,430* (21,430*)	16,940* (16,940*)	14,280* (14,300*)	10,790 (12,560*)	8,520 (10,150*)
10	non supported	(18,430)	(12,110)	(8,800)	(6,770)	(5,390)
	4-pt. supported	26,120* (26,120*)	19,080* (19,080*)	13,840 (15,400*)	10,560 (13,100*)	8,420 (10,440)
5	non supported	(17,020)	(11,420)	(8,430)	(6,560)	(5,290)
	4-pt. supported	21,490* (21,490*)	18,730 (20,880*)	13,430 (16,330*)	10,330 (12,910)	8,310 (10,330)
0	non supported	(15,390*)	(10,970)	(8,150)	(6,400)	(5,230)
	4-pt. supported	15,390* (15,390*)	18,210 (21,630*)	13,120 (16,640)	10,160 (12,730)	8,250 (10,260)
-5	non supported		(10,790)	(8,020)	(6,340)	
	4-pt. supported		18,000 (20,990*)	12,970 (16,340*)	10,090 (16,340)	

RECOMMENDED ATTACHMENTS*

Lift Hook	22046 lbs (10 t)
Terex® Cactus Grab	0.52 yd ³ open or half-closed tines
Terex® Cactus Grab	0.78 yd ³ open or half-closed tines
Terex® Cactus Grab	1.0 yd ³ open or half-closed tines
Clamshell Grab	1.3 yd ³ density to 2360 lbs/yd ³
Clamshell Grab	2.0 yd ³ density to 1348 lbs/yd ³
Terex® Magnet Plate MP 1250	diameter 49 in with 13 kW magnet system

* May vary depending on material being handled and operating conditions.

Capacity values are stated in lbs. The pump pressure is 5,221 psi (360 bar). The values, in accordance with ISO 10567, amount to 75% of the static tipping load or 87% of the hydraulic lifting force (marked *). They apply to slewing operations through 360° on a firm and level surface.

Values in parentheses apply to the longitudinal direction of the undercarriage. "Non-supported" values apply when the load is hoisted above the front or rear axle.

The weight of the attached hoisting equipment (grab, magnet, coupler, lift hook, etc.) must be deducted from the capacity values. Load holding valves on the lift cylinders and an overload warning device are required for crane operations.

WORKS FOR YOU.™

WORKING RANGES

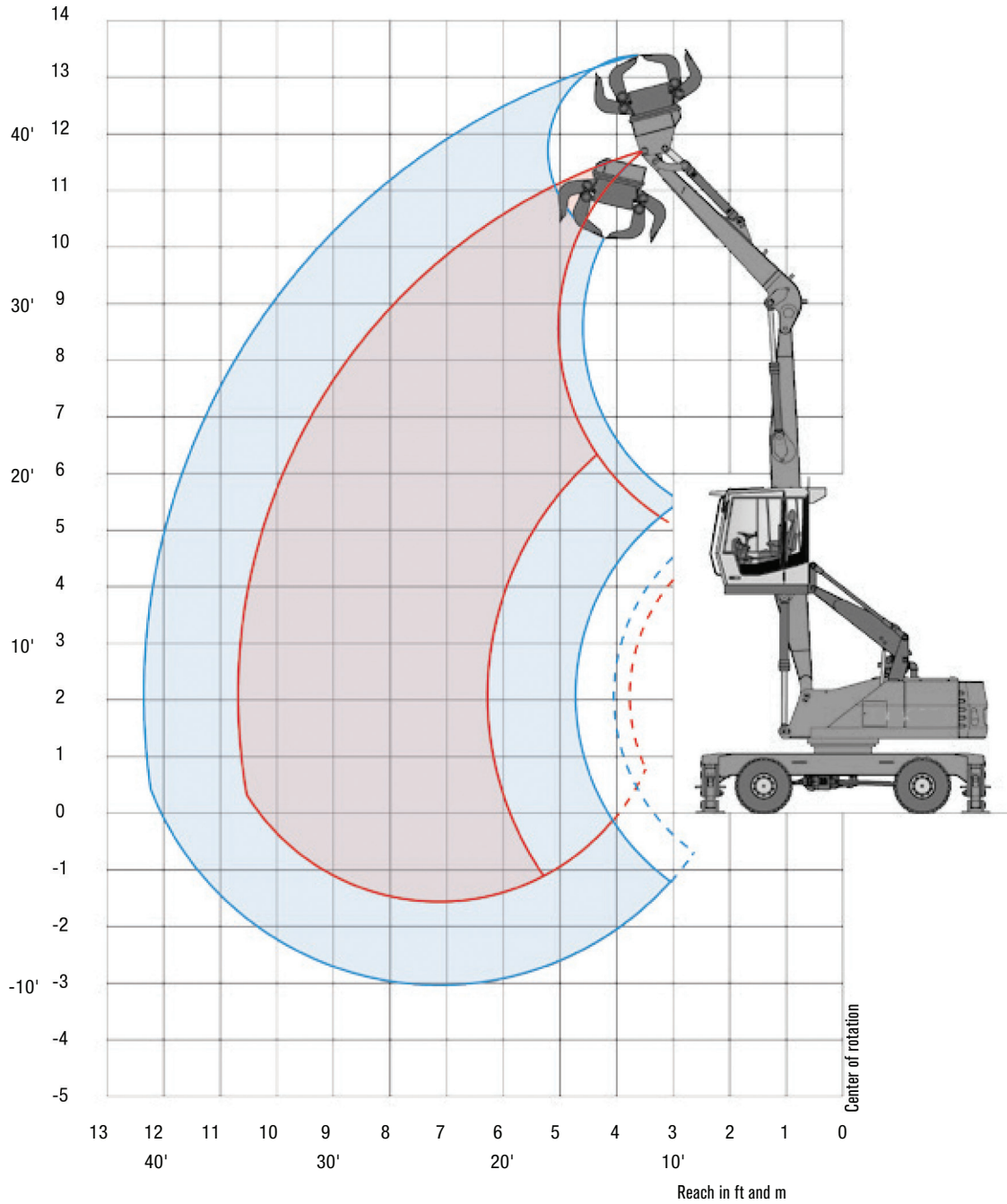

Reach 35 ft

Work equipment:
Box-type boom 21.3 ft
Multi-purpose stick 13.1 ft
Sorting grab

LIFTING CAPACITIES

TMH335

HEIGHT ft	UNDERCARRIAGE STABILIZERS	REACH ft				
		15	20	25	30	35
35	non supported		(11,060*)			
	4-pt. supported		11,060* (11,060*)			
30	non supported		(13,250)	(9,060)		
	4-pt. supported		14,220* (14,220*)	11,420* (11,420*)		
25	non supported		(13,170)	(9,100)	(6,600)	
	4-pt. supported		14,280* (14,280*)	(12,790*) (12,790*)	(9,180*) (9,180*)	
20	non supported	(18,470*)	(12,790)	(8,910)	(6,560)	
	4-pt. supported	18,470* (18,470*)	15,250* (15,250*)	13,220* (13,220*)	10,380 (11,840*)	
15	non supported	(19,170)	(12,150)	(8,580)	(6,410)	
	4-pt. supported	22,090* (22,090*)	16,950* (16,950*)	13,650 (14,060*)	10,210 (12,190*)	
10	non supported	(17,420)	(11,380)	(8,180)	(6,200)	(4,850)
	4-pt. supported	26,530* (26,530*)	18,760 (18,950*)	13,210 (15,050*)	9,990 (12,570)	7,880 (9,900)
5	non supported	(16,130)	(10,720)	(7,820)	(6,000)	(4,770)
	4-pt. supported	16,490* (16,490*)	18,010 (20,470*)	12,810 (15,830*)	9,770 (12,350)	7,790 (9,810)
0	non supported	(13,950*)	(10,330)	(7,570)	(5,870)	
	4-pt. supported	13,950* (13,950*)	17,550 (20,850)	12,540 (16,030)	9,630 (12,190)	
-5	non supported			(7,470)		
	4-pt. supported			12,430 (15,320*)		

Capacity values are stated in lbs. The pump pressure is 5,221 psi (360 bar). The values, in accordance with ISO 10567, amount to 75% of the static tipping load or 87% of the hydraulic lifting force (marked *). They apply to slewing operations through 360° on a firm and level surface.

Values in parentheses apply to the longitudinal direction of the undercarriage. "Non-supported" values apply when the load is hoisted above the front or rear axle.

The weight of the attached hoisting equipment (grab, magnet, coupler, lift hook, etc.) must be deducted from the capacity values. Load holding valves on the lift cylinders and an overload warning device are required for crane operations.

WORKS FOR YOU.™



ENVIRONMENTAL EQUIPMENT

CONTACT DETAILS

Terex Environmental Equipment
1250 Commerce Drive
Farwell, Michigan 48622
USA

Toll Free: 1-800-953-5532
Phone: 1-989-588-4295
Fax: 1-989-588-4827
E Mail: salesenvironmental@terex.com
Website: www.terex.com/environmental-equipment

CUSTOMER SERVICE

Technical Helpdesk Support
Tom Feichtinger
Tel: 1 (989) 339 2060
E-mail: Thomas.feichtinger@terex.com

Customer Service Representative
Jeff Hohlbein
Tel: 1 (989) 339 2062
E-mail: jeff.hohlbein@terex.com



SOCIAL NETWORKING



Become a Terex fan on Facebook by visiting
www.facebook.com/terexcorporation



Check out Terex Videos on YouTube:
www.youtube.com/TerexEnviroEquip



WORKS FOR YOU.

The material in this document is for information only and is subject to change without notice.

Terex assumes no liability resulting from errors or omissions in this document, or from the use of the information contained herein. Due to continual product development we reserve the right to change specifications without notice. Product performance figures given in this brochure are for guidance purposes only, this information does not constitute an expressed or implied warranty or guarantee, but shows test examples. These results will vary depending on feed source and types of material being used.

Photographs are for illustrative purposes only, some or all of the machines in the illustrations may have been fitted with optional extras. Please check for details on optional extras.

Products and services listed may be trademarks, service marks or trade-names of Terex Corporation and/or its subsidiaries in the USA and other countries. All rights reserved. Terex is a registered trademark of Trade Corporation in the USA and many other countries. ©2013 Terex Corporation.

©2013 Terex Corporation