



AGGREGATES Sand & Gravel

*water treatment
and silt dewatering plants*

matec[®]

machinery technology

“The three Cs for the founders and their companies’ success are: Capacity, Competence, Courtesy.”

COMPANY

Company

Matec specializes in the design and development of waste water purification and filtration plants. We work for many different industries, the most important are: aggregates, gravel, sand, coal, stone, iron-ore, ceramics and glass.

Matec's mission is our customers' satisfaction. That is why we offer timely after-sale service, as well as before-sale advice to understand the real requirements of our potential customers.

Matec has installed over 250 purification plants all across the world in the last two years: this is the real guarantee of our production and service quality.

The two partners have decades-old experience in the purification industry and they are a continued presence in the company. That guarantees the best technical and commercial advice ever.

Matec new plants are based in Massa, in the very heart of a wide industrial zone, also known as Apuana. A well-equipped reality that can cope with all the needs of the worldwide purification market, thanks to a simple but effective organization.

All the machines are built in our plants. Thus we can offer top-quality products 'Made in Italy', which will fulfill the most demanding applications and markets.



Aggregates - Sand & Gravel

Matec is a technology leader and the leading producer of machines for filtration and mining activities, as well as for water purification.

Treatment of sludge arising from sand washing.

Matec designs and manufactures complete filtration systems in the major fine sand recovery sites. There filter presses are used in sludge treatment, to recover and recycle sands whose value is increasing and to dispose of chemical wastes.

Matec treatment plants are designed to maximize the returns of sand washing plants.

We have developed extensive experience in treating by-product sludge of sand and gravel quarries, resulting from sand washing.

The mineral sector includes: Sedimentary, Igneous, Methamorphics (like sandstone, limestone, clay, carbonate, caolin, caorse, granite, marble, tout-venant).

CLASSIFICATION OF ROCKS

Sedimentary: Chemical (Limestone, Dolostone, Evaporites), Clastic (Conglomerate, Breccia, Sandstone, Siltstone, Mudstone, Shale) Biologic (Coal, Chert)

Igneous: Intrusive (Gabbro, Diorite, Granodiorite, granite), Extrusive (Basalt, Andesite, Dacite, Rhyolite)

Metamorphic: Foliated (Slate, Schist, Gneiss), Non-foliated (Quartzite, Marble)

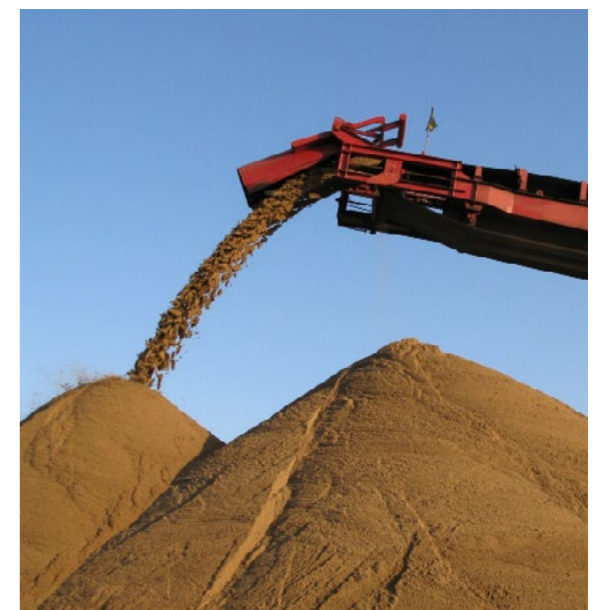

Acquæ 400/500/630

Perfect for small and medium production plants specialized in aggregates, sand and gravel treatment in quarries and mines.
Acquæ 400-500-630. It is named after the Latin word for Water, because it was created as a project designed for the recovery of water even in case of minimum flow rates. Because water is life!

The Acquæ is our small-medium range. It includes the technical specifications of the bigger machines simplified for uses in fields such as:
Marble and granite sector, small and medium workshops with flow rates up to 60-120-400m³/h;
Ceramic sector, factories with flow rates of waste water up to 90-200-500m³/h;
Cement sector, BWR for the recycling of concrete recovered from cement mixers;
High technology and refinement mining sector;
Aggregates and recycling sector, flow rates up to 60 m³/h.

Benefits :

- 100% Made in ITALY. 100% Made in Tuscany
- HPT (High Pressure Technology) to work at more than 20 BAR
- Gasser Shakers for discharging the cakes perfectly
- Real automatic washing for a complete washing
- Filter cloths attached with strips and rubber connection for an easy replacement
- Open filtrate design allows a simple and rapid identification of bad filter cloths
- Allen Bradley PLC with remote monitoring and assistance
- Number of installed plates can be up to 50 in all presses
- More than 20 models for the best economical/technical solutions

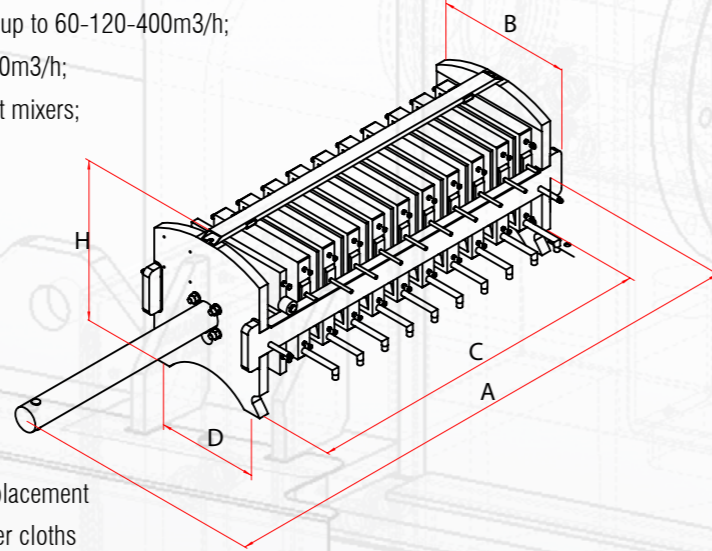

Specifications

Acquæ model 400x400	A Length	B Width	C Foot Footbase	D Foot Footbase	H Total Height	Dry Weight (Kg)	Chamber Volume (Liters)	Capacity per cycle (Liters)	m ³ /h (2 cycles)	Ton/h	m ³ /h (3 cycles)
400/3	2485	770	750	430	800	350	4,9	9,80	0,02	0,04	0,03
400/5	2485	770	750	430	800	350	4,9	24,50	0,05	0,09	0,07
400/10	2485	770	1340	430	800	450	4,9	49,00	0,10	0,18	0,15
400/15	3235	770	1932	430	800	500	4,9	73,50	0,15	0,27	0,22
400/20	3235	770	1932	430	800	600	4,9	98,00	0,20	0,36	0,29
400/25	6149	770	3712	430	800	1200	4,9	122,50	0,25	0,45	0,37
400/30	6149	770	3712	430	800	1300	4,9	147,00	0,29	0,54	0,44

Specifications

Acquæ model 500x500	A Length	B Width	C Foot Footbase	D Foot Footbase	H Total Height	Dry Weight (Kg)	Chamber Volume (Liters)	Capacity per cycle (Liters)	m ³ /h (2 cycles)	Ton/h	m ³ /h (3 cycles)
500/10	2.300	770	1.330	430	800	800	5,9	59,00	0,12	0,22	0,18
500/15	3.380	770	2.000	430	800	1.000	5,9	88,50	0,18	0,33	0,27
500/20	4.040	770	2.430	430	800	1.200	5,9	118,00	0,24	0,44	0,35
500/25	4.660	770	2.850	430	800	1.300	5,9	147,50	0,30	0,55	0,44
500/30	5.260	770	3.270	430	800	1.500	5,9	177,00	0,35	0,65	0,53

Specifications

Acquæ model 630x630	A Length	B Width	C Foot Footbase	D Foot Footbase	H Total Height	Dry Weight (Kg)	Chamber Volume (Liters)	Capacity per cycle (Liters)	m ³ /h (2 cycles)	Ton/h	m ³ /h (3 cycles)
630/10	2.880	1.200	1.545	770	1.565	2.600	12,5	125,00	0,25	0,46	0,38
630/15	5.290	1.200	2.885	770	1.565	3.500	12,5	187,50	0,38	0,69	0,56
630/20	5.290	1.200	2.885	770	1.565	3.500	12,5	250,00	0,50	0,93	0,75
630/25	6.175	1.200	3.555	770	1.565	3.800	12,5	312,50	0,63	1,16	0,94
630/30	7.300	1.200	4.255	770	1.565	4.000	12,5	375,00	0,75	1,39	1,13
630/40	9.610	1.200	5.685	770	1.565	4.300	12,5	500,00	1,00	1,85	1,50
630/50	11.825	1.200	7.070	770	1.565	4.600	12,5	625,00	1,25	2,31	1,88

Ignis 800x800

Perfect for medium production plants specialized in aggregates, sand and gravel treatment in quarries and mines.
Ignis 800x800. It is named after the Latin word for Fire, because it is created from materials welded with fire.
The Ignis 800x800 is our medium range. It includes the technical specifications of the bigger machines for uses in fields such as:
Marble and granite sector, small and medium workshops with flow rates up to 700m³/h;
Ceramic sector, factories with flow rates of waste water up to 900m³/h;
Cement sector, BWR for the recycling of concrete recovered from cement mixers;
High technology and refinement mining sector;
Aggregates and recycling sector, flow rates up to 120m³/h.

Benefits :

- 100% Made in ITALY. 100% Made in Tuscany
- HPT (High Pressure Technology) to work at more than 20 BAR
- Gasser Shakers for discharging the cakes perfectly
- Real automatic washing for a complete washing
- Filter cloths attached with strips and rubber connection for an easy replacement
- Open filtrate design allows a simple and rapid identification of bad filter cloths
- Allen Bradley PLC with remote monitoring and assistance
- Number of installed plates can be up to 70 in all presses
- More than 10 models for the best economical/technical solutions

Filters with 50 or more plates include the TT2Fast model (fast opening):
The TT2fast opening can discharge the cakes for 100 plates in less than 2 minutes

- All made of single-block steel from thick slabs*
- Plasma, laser or water-jet manufacturing process*
- The purified water is drained through 4 external manifolds (to avoid external contacts or leaks)*
- First choice components by major manufacturers*
- Stainless steel accessories*
- High speed and high pressure hydraulic system*
- Gasser Shaker automatic system for discharging the cakes*
- Cloth and plate automatic washing*
- PLC switchboard to control the whole system electronically.*

Specifications

Ignis model 800x800	A Length	B Width	C Foot Footbase	D Foot Footbase	H Total Height	Dry Weight (Kg)	Chamber Volume (Liters)	Capacity per cycle (Liters)	m ³ /h (2 cycles)	Ton/h	m ³ /h (3 cycles)
800/10	4.585	1.530	2.455	890	1.760	2.600	18,2	182,00	0,36	0,67	0,55
800/15	4.235	1.530	2.455	890	1.760	3.000	18,2	273,00	0,55	1,01	0,82
800/20	5.300	1.530	3.160	890	1.760	3.600	18,2	364,00	0,73	1,35	1,09
800/25	7.900	1.530	4.575	890	1.760	4.500	18,2	455,00	0,91	1,68	1,37
800/30	7.900	1.530	4.575	890	1.760	4.500	18,2	546,00	1,09	2,02	1,64
800/40	8.120	1.530	5.980	890	1.760	5.500	18,2	728,00	1,46	2,69	2,18
800/50 New TT	5.776	1.530	4.518	890	1.760	6.000	18,2	910,00	1,82	3,37	2,73
800/60 New TT	6.398	1.530	5.140	890	1.760	6.600	18,2	1.092,00	2,18	4,04	3,28
800/70 New TT	7.206	1.530	5.948	890	1.760	7.200	18,2	1.274,00	2,55	4,71	3,82

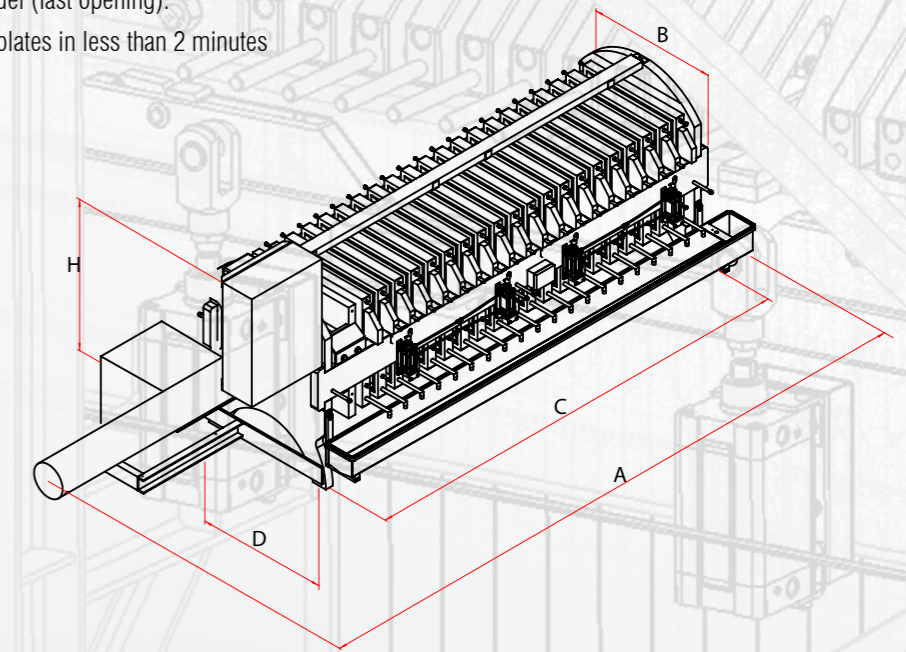



PROJECT
Beton Wash - France

matec[®]
machinery technology

PROJECT
KSD - United Kingdom

Ignis 1000x1000

Perfect for medium production plants specialized in aggregates, sand and gravel treatment in quarries and mines.

Ignis 1000x1000. It is named after the Latin word for Fire, because it is created from materials welded with fire.

The Ignis 1000x1000 is our medium range. It includes the technical specifications of the bigger machines for uses in fields such as:

Marble and granite sector, small and medium workshops with flow rates up to 2500m³/h;

Ceramic sector, factories with flow rates of waste water up to 3000m³/h;

Cement sector, BWR for the recycling of concrete recovered from cement mixers;

High technology and refinement mining sectors such as Iron-Ore, Coal, Silver, Gold, and in general Ferrous and Non-Ferrous ones;

Aggregates and recycling sector, flow rates up to 300m³/h.

Benefits :

- 100% Made in ITALY. 100% Made in Tuscany
- HPT (High Pressure Technology) to work at more than 20 BAR
- Gasser Shakers for discharging the cakes perfectly
- Real automatic washing for a complete washing
- Filter cloths attached with strips and rubber connection for an easy replacement
- Open filtrate design allows a simple and rapid identification of bad filter cloths
- Allen Bradley PLC with remote monitoring and assistance
- Number of installed plates can be up to 150 in all presses
- More than 15 models for the best economical/technical solutions

Filters with 50 or more plates include the TT2Fast model (fast opening):

The TT2fast opening can discharge the cakes for 100 plates in less than 2 minutes

and for 150 plates in less than 3.5 minutes

All made of single-block steel from thick slabs

Plasma, laser or water-jet manufacturing process

The purified water is drained through 4 external manifolds

(to avoid external contacts or leaks)

First choice components by major manufacturers

Stainless steel accessories

High speed and high pressure hydraulic system

Gasser Shaker automatic system for discharging the cakes

Cloth and plate automatic washing

PLC switchboard to control the whole system electronically

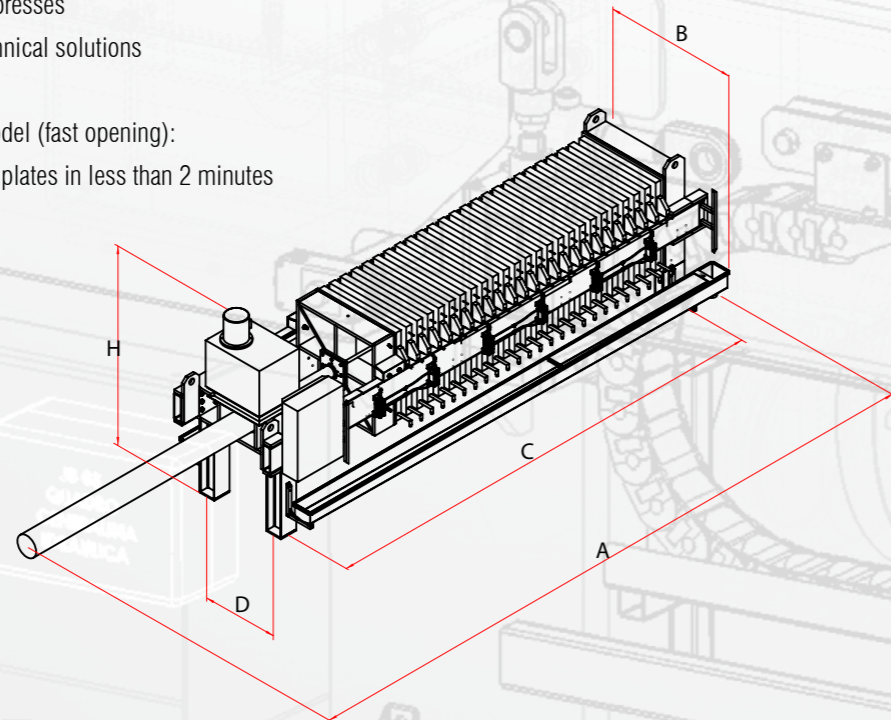

Specifications

Ignis model 1000x1000	A Length	B Width	C Foot Footbase	D Foot Footbase	H Total Height	Dry Weight (Kg)	Chamber Volume (Liters)	Capacity per cycle (Liters)	m ³ /h (2 cycles)	Ton/h	m ³ /h (3 cycles)
1000/15	5.020	1.840	3.035	870	2.135	4.000	29,1	436,50	0,87	1,62	1,31
1000/20	6.010	1.840	3.745	870	2.135	4.500	29,1	582,00	1,16	2,15	1,75
1000/25	6.670	1.840	4.035	870	2.135	5.000	29,1	727,50	1,46	2,69	2,18
1000/30	8.190	1.840	5.195	870	2.135	5.000	29,1	873,00	1,75	3,23	2,62
1000/40	10.115	1.840	6.515	870	2.135	5.500	29,1	1.164,00	2,33	4,31	3,49
1000/50 New TT	7.600	1.730	5.450	870	2.155	7.000	29,1	1.455,00	2,91	5,38	4,37
1000/60 New TT	8.080	1.730	5.940	870	2.155	7.500	29,1	1.746,00	3,49	6,46	5,24
1000/70 New TT	9.080	1.730	6.940	870	2.155	8.100	29,1	2.037,00	4,07	7,54	6,11
1000/80 New TT	9.842	1.730	7.700	870	2.155	8.700	29,1	2.328,00	4,66	8,61	6,98
1000/90 New TT	9.480	1.730	7.340	870	2.155	9.300	29,1	2.619,00	5,24	9,69	7,86
1000/100 New TT	11.355	1.730	9.213	870	2.155	10.000	29,1	2.910,00	5,82	10,77	8,73
1000/120 New TT	12.805	1.730	10.900	870	2.155	12.500	29,1	3.492,00	6,98	12,92	10,48

Terræ 1200x1200/1300x1300

Perfect for medium and large production plants specialized in aggregates, sand and gravel treatment in quarries and mines.

Terræ 1200x1200/1300x1300. It is named after the Latin word for Earth, because it is specially created for and completely dedicated to every kinds of applications in quarries and mines, that is to say for areas where men use the Earth for progress.

The Terræ 1200x1200/1300x1300 is our medium range. It includes the technical specifications of the bigger machines for uses in fields such as:

Aggregates and recycling sector, flow rates up to 500m³/h;

High technology and refinement mining sectors such as Iron-Ore, Coal, Silver, Gold, and in general Ferrous and Non-Ferrous ones.

Benefits :

- 100% Made in ITALY. 100% Made in Tuscany
- HPT (High Pressure Technology) to work at more than 20 BAR
- Gasser Shakers for discharging the cakes perfectly
- Real automatic washing for a complete washing
- Filter cloths attached with strips and rubber connection for an easy replacement
- Open filtrate design allows a simple and rapid identification of bad filter cloths
- Allen Bradley PLC with remote monitoring and assistance
- Number of installed plates can be up to 180 in all presses
- More than 20 models for the best economical/technical solutions

Filters with 50 or more plates include the TT2Fast model (fast opening):

The TT2fast opening can discharge the cakes for 100 plates in less than

2 minutes and for 180 plates in less than 3.5 minutes

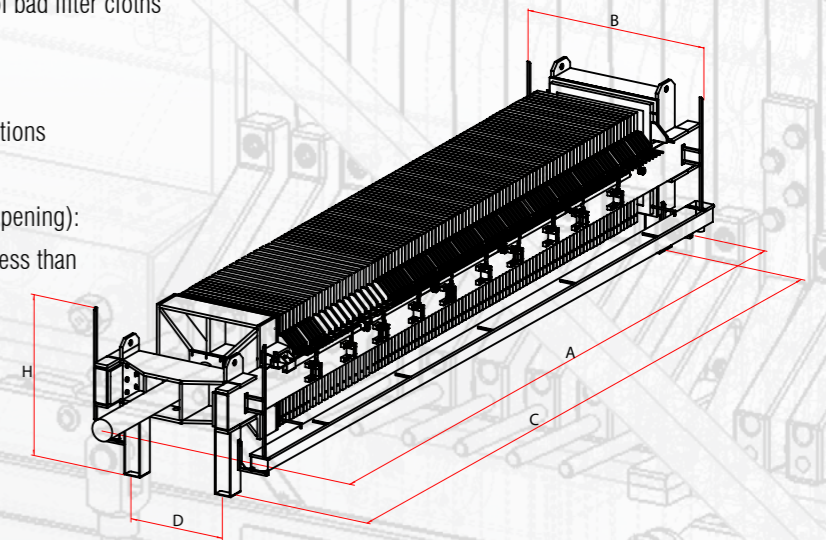

Specifications

Terræ model 1200x1200	A Length	B Width	C Foot Footbase	D Foot Footbase	H Total Height	Dry Weight (Kg)	Chamber Volume (Liters)	Capacity per cycle (Liters)	m ³ /h (2 cycles)	Ton/h	m ³ /h (3 cycles)
1200/50 New TT	8.173	2.270	6.050	1.170	2.060	13.200	39	1.950,00	3,90	7,22	5,85
1200/60 New TT	9.850	2.270	7.120	1.170	2.060	14.500	39	2.340,00	4,68	8,66	7,02
1200/70 New TT	9.363	2.270	7.312	1.170	2.060	15.800	39	2.730,00	5,46	10,10	8,19
1200/80 New TT	10.469	2.270	8.344	1.170	2.060	17.100	39	3.120,00	6,24	11,54	9,36
1200/90 New TT	10.700	2.270	8.575	1.170	2.060	18.400	39	3.510,00	7,02	12,99	10,53
1200/100 New TT	11.863	2.270	9.740	1.170	2.060	20.000	39	3.900,00	7,80	14,43	11,70
1200/120 New TT	12.723	2.270	10.600	1.170	2.060	22.000	39	4.680,00	9,36	17,32	14,04

Specifications

Terræ model 1300x1300	A Length	B Width	C Foot Footbase	D Foot Footbase	H Total Height	Dry Weight (Kg)	Chamber Volume (Liters)	Capacity per cycle (Liters)	m ³ /h (2 cycles)	Ton/h	m ³ /h (3 cycles)
1300/15	5.388	2.270	3.465	1.170	2.060	6.000	47,3	709,50	1,42	2,63	2,13
1300/20	5.580	2.270	3.475	1.170	2.060	8.500	47,3	946,00	1,89	3,50	2,84
1300/25	7.410	2.270	4.955	1.170	2.060	10.000	47,3	1.182,50	2,37	4,38	3,55
1300/30	9.850	2.270	6.995	1.170	2.060	11.500	47,3	1.419,00	2,84	5,25	4,26
1300/40	11.680	2.270	8.425	1.170	2.060	13.000	47,3	1.892,00	3,78	7,00	5,68
1300/50 New TT	8.173	2.270	6.050	1.170	2.060	13.200	47,3	2.365,00	4,73	8,75	7,10
1300/60 New TT	9.850	2.270	7.120	1.170	2.060	14.500	47,3	2.838,00	5,68	10,50	8,51
1300/70 New TT	9.363	2.270	7.312	1.170	2.060	15.800	47,3	3.311,00	6,62	12,25	9,93
1300/80 New TT	10.469	2.270	8.344	1.170	2.060	17.100	47,3	3.784,00	7,57	14,00	11,35
1300/90 New TT	10.700	2.270	8.575	1.170	2.060	18.400	47,3	4.257,00	8,51	15,75	12,77
1300/100 New TT	11.863	2.270	9.740	1.170	2.060	20.000	47,3	4.730,00	9,46	17,50	14,19
1300/120 New TT	12.723	2.270	10.600	1.170	2.060	22.000	47,3	5.676,00	11,35	21,00	17,03

matec[®]
machinery technology

PROJECT
Mondial Sabbia - Italy



matec[®]
machinery technology

PROJECT
AGGCORP - Ohio



Terræ 1500x1500

Perfect for large production plants specialized in aggregates, sand and gravel treatment in quarries and mines. Terræ 1500x1500. It is named after the Latin word for Earth, because it is specially created for and completely dedicated to every kinds of applications in quarries and mines, that is to say for areas where men use the Earth for progress. The Terræ 1500x1500 is our big range. It includes the latest and best technologies and technical specifications. This model is available both in side-beams and over-beams:

Aggregates and recycling sector, flow rates up to 900m³/h;

High technology and refinement mining sectors such as Iron-Ore, Coal, Silver, Gold, and in general Ferrous and Non-Ferrous ones.

Benefits :

- 100% Made in ITALY. 100% Made in Tuscany
- HPT (High Pressure Technology) to work at more than 20 BAR
- Gasser Shakers for discharging the cakes perfectly
- Real automatic washing for a complete washing
- Filter cloths attached with strips and rubber connection for an easy replacement
- Open filtrate design allows a simple and rapid identification of bad filter cloths
- Allen Bradley PLC with remote monitoring and assistance
- Number of installed plates can be up to 180 in all presses
- More than 15 models for the best economical/technical solutions

Filters with 50 or more plates include the TT2Fast model (fast opening):

The TT2fast opening can discharge the cakes for 100 plates in less than 2 minutes and for 180 plates in less than 3.5 minutes

All made of single-block steel from thick slabs

Plasma, laser or water-jet manufacturing process

The purified water is drained through 4 external manifolds

(to avoid external contacts or leaks)

First choice components by major manufacturers

Stainless steel accessories

High speed and high pressure hydraulic system

Gasser Shaker automatic system for discharging the cakes

Cloth and plate automatic washing

PLC switchboard to control the whole system electronically.

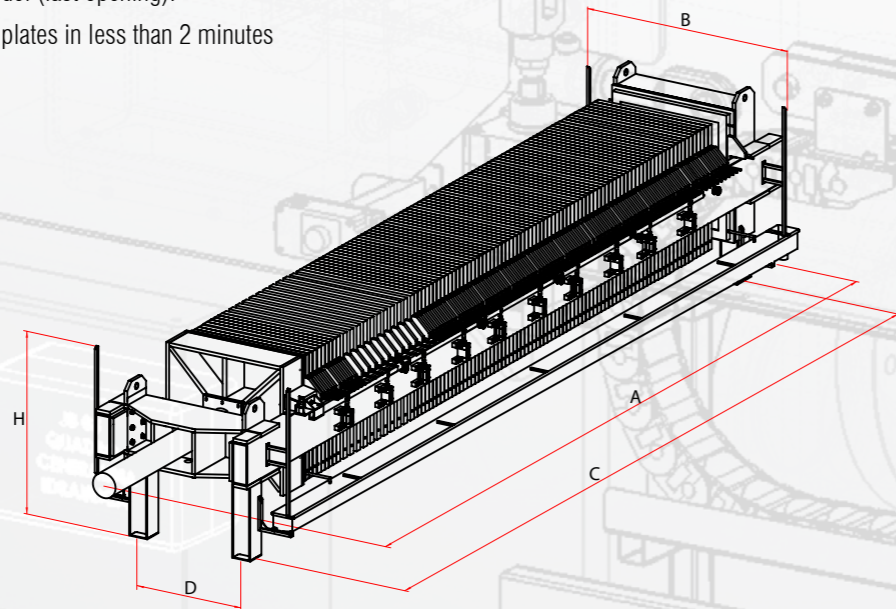

Specifications

Terræ model 1500x1500	A Length	B Width	C Foot Footbase	D Foot Footbase	H Total Height	Dry Weight (Kg)	Chamber Volume (Liters)	Capacity per cycle (Liters)	m ³ /h (2 cycles)	Ton/h	m ³ /h (3 cycles)
1500/30	8.475	2.505	5.470	1.360	2.270	12.000	63,1	1.893,00	3,79	7,00	5,68
1500/40	11.700	2.505	7.600	1.360	2.270	13.700	63,1	2.524,00	5,05	9,34	7,57
1500/50 New TT	8.542	2.505	6.360	1.360	2.270	15.800	63,1	3.155,00	6,31	11,67	9,47
1500/60 New TT	9.300	2.505	6.840	1.360	2.270	17.800	63,1	3.786,00	7,57	14,01	11,36
1500/70 New TT	10.200	2.505	8.020	1.360	2.270	19.800	63,1	4.417,00	8,83	16,34	13,25
1500/80 New TT	11.022	2.505	8.840	1.360	2.270	21.500	63,1	5.048,00	10,10	18,68	15,14
1500/90 New TT	11.680	2.505	9.265	1.360	2.270	24.000	63,1	5.679,00	11,36	21,01	17,04
1500/100 New TT	12.635	2.505	10.415	1.360	2.270	25.000	63,1	6.310,00	12,62	23,35	18,93
1500/120 New TT	12.635	2.505	10.415	1.360	2.270	29.000	63,1	7.572,00	15,14	28,02	22,72
1500/140 New TT	15.825	2.505	14.100	1.360	2.270	33.000	63,1	8.834,00	17,67	32,69	26,50
1500/150 New TT	16.842	2.505	14.660	1.360	2.270	37.000	63,1	9.465,00	18,93	35,02	28,40
1500/160 New TT	17.672	2.505	15.490	1.360	2.270	41.000	63,1	10.096,00	20,19	37,36	30,29

Terræ 1500x2000

Perfect for large plants specialized in aggregates, sand and gravel treatment in quarries and mines. Terræ 1500x2000. It is named after the Latin word for Earth, because it was specially created for and completely dedicated to every kinds of applications in quarries and mines, that is to say for areas where men use the Earth for progress. The Terræ 1500x2000 is our big range. It is perfect for all heavy-duty sectors and includes the latest and best technologies and technical specifications. This model is available both in side-beams and over-beams:

Aggregates and recycling sector, flow rates up to 1500m³/h;

High technology and refinement mining sectors such as Iron-Ore, Coal, Silver, Gold, and in general Ferrous and Non-Ferrous ones.

Benefits :

- 100% Made in ITALY. 100% Made in Tuscany
- HPT (High Pressure Technology) to work at more than 20 BAR
- Gasser Shakers for discharging the cakes perfectly
- Real automatic washing for a complete washing
- Filter cloths attached with strips and rubber connection for an easy replacement
- Open filtrate design allows a simple and rapid identification of bad filter cloths
- Allen Bradley PLC with remote monitoring and assistance
- Number of installed plates can be up to 200 in all presses
- More than 10 models for the best economical/technical solutions

Filters with 50 or more plates include the TT2Fast model (fast opening):

The TT2fast opening can discharge the cakes for 100 plates in less than 2 minutes and for 200 plates in less than 4 minutes

All made of single-block steel from thick slabs

Plasma, laser or water-jet manufacturing process

The purified water is drained through 4 external manifolds

(to avoid external contacts or leaks)

First choice components by major manufacturers

Stainless steel accessories

High speed and high pressure hydraulic system

Gasser Shaker automatic system for discharging the cakes

Cloth and plate automatic washing

PLC switchboard to control the whole system electronically.

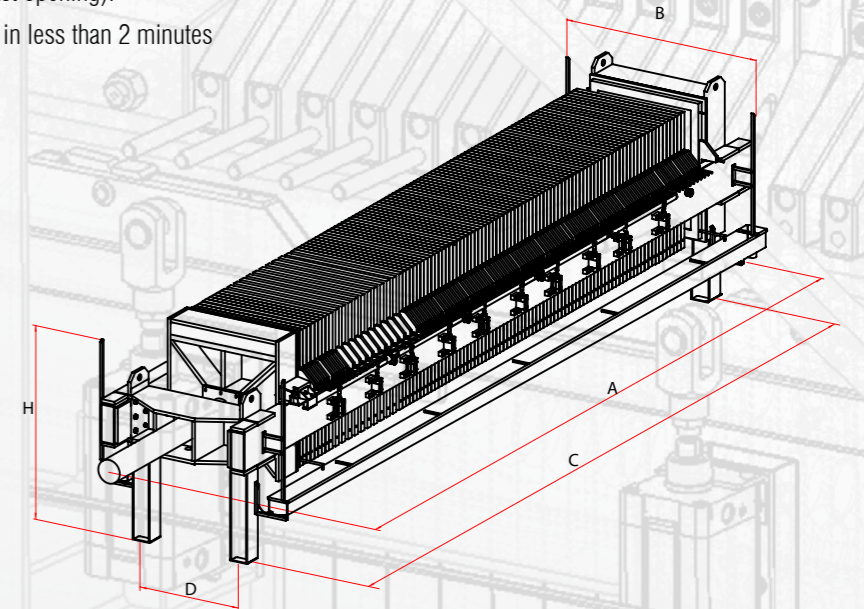

Specifications

Terræ model 1500x2000	A Length	B Width	C Foot Footbase	D Foot Footbase	H Total Height	Dry Weight (Kg)	Chamber Volume (Liters)	Capacity per cycle (Liters)	m ³ /h (2 cycles)	Ton/h	m ³ /h (3 cycles)
1500/50 New TT	8.270	2.793	6.030	1.310	2.896	24.200	85,11	4.255,50	8,51	15,75	12,77
1500/60 New TT	9.470	2.793	7.230	1.310	2.896	24.900	85,11	5.106,60	10,21	18,89	15,32
1500/70 New TT	10.280	2.793	8.100	1.310	2.896	25.600	85,11	5.957,70	11,92	22,04	17,87
1500/80 New TT	11.120	2.793	8.940	1.310	2.896	27.300	85,11	6.808,80	13,62	25,19	20,43
1500/90 New TT	11.960	2.793	9.780	1.310	2.896	29.200	85,11	7.659,90	15,32	28,34	22,98
1500/100 New TT	12.800	2.793	10.620	1.310	2.896	31.200	85,11	8.511,00	17,02	31,49	25,53
1500/120 New TT	14.480	2.793	12.300	1.310	2.896	33.100	85,11	10.213,20	20,43	37,79	30,64
1500/140 New TT	16.160	2.793	13.980	1.310	2.896	35.200	85,11	11.915,40	23,83	44,09	35,75
1500/160 New TT	17.840	2.793	15.660	1.310	2.896	37.500	85,11	13.617,60	27,24	50,39	40,85
1500/180 New TT	19.520	2.793	17.340	1.310	2.896	39.800	85,11	15.319,80	30,64	56,68	45,96
1500/200 TwinNewTT	21.200	2.793	19.020	1.310	2.896	42.800	85,11	17.022,00	34,04	62,98	51,07

A large industrial water treatment facility. On the left is a tall, cylindrical stainless steel tank supported by a complex metal lattice structure. To the right is a concrete structure with a platform. On the platform, there is a large red machine, possibly a filter or pump, and a person is visible. The background shows a rocky, excavated hillside with green trees. In the foreground, there is a pile of brown, fragmented material. A red banner is overlaid on the bottom left.

PROJECT
Fassa Bortolo - Italy

Q8
Oil

matec[®]

machinery technology

PROJECT
Kealshore - United Kingdom

*“Our aim is to provide heavy
duty works 24/24, 7/7, 12/12.”*

matec[®]
machinery technology

PROJECT
Nobile - Italy



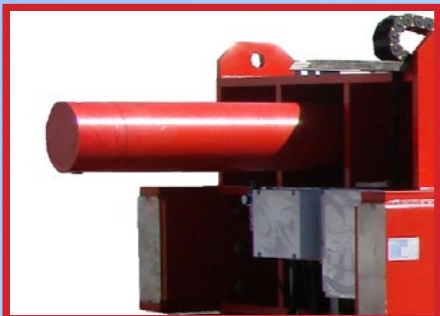

TESTED 10.000 PSI
(700 BAR)



TT2FAST
THE FASTER OPENING



OPEN FILTRATE DESIGN



AUTOMATIC REAL WASHING



SHAKER "GASSER"



HIGH THICKNESS STEEL

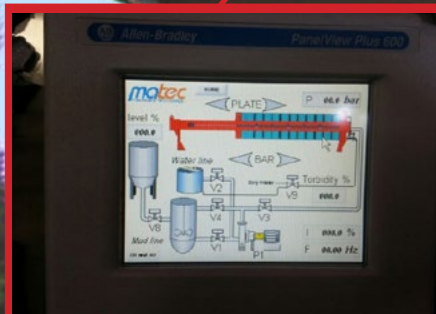

ALLEN BRADLEY
SIEMENS TECHNOLOGY

matec[®]
machinery technology

BORN TO BE PERFECT
TURNKEY WATER TREATMENT
AND FILTER PRESS

NO PERSON, NO POLYMER, NO PROBLEMS!

Turn Hard-To-Handle Sludge Into Easy-To-Handle Dry Cakes
With The Matec Plate & Frame Press



MOISTURE < 20%



20 BAR

matec[®]
machinery technology

PROJECT
Cave del Ticino - Italy



matec[®]
machinery technology

PROJECT
Latomia Farmaka - Cyprus





PROJECT
Fulchiron - France

MAGNUM 2000x2000

Perfect for very large plants specialized in aggregates, earth and gravel treatment in quarries and mines.

Magnum 2000x2000. It is named after the Latin word for Magnificent, because it is our top-of-the-range machine, created for and completely dedicated to every kinds of applications in quarries and mines, that is to say for areas where men use the Earth for progress.

The Magnum 2000x2000 is our biggest range. It is perfect for all heavy-duty sectors and includes the latest and best technologies and technical specifications. This model is available both in side-beams and over-beams:

Aggregates and recycling sector, flow rates up to 2000m³/h;

High technology and refinement mining sector such as Iron-Ore, Coal, Silver, Gold, and in general Ferrous and Non-Ferrous ones.

Benefits :

- 100% Made in ITALY. 100% Made in Tuscany
- HPT (High Pressure Technology) to work at more than 20 BAR
- Gasser Shakers for discharging the cakes perfectly
- Real automatic washing for a complete washing
- Filter cloths attached with strips and rubber connection for an easy replacement
- Open filtrate design allows a simple and rapid identification of bad filter cloths
- Allen Bradley PLC with remote monitoring and assistance
- Number of installed plates can be up to 200 in all presses
- More than 5 models for the best economical/technical solutions

Filters with 50 or more plates include the TT2Fast model (fast opening):

The TT2fast opening can discharge the cakes for 100 plates in less than 2 minutes and for 200 plates in less than 4 minutes

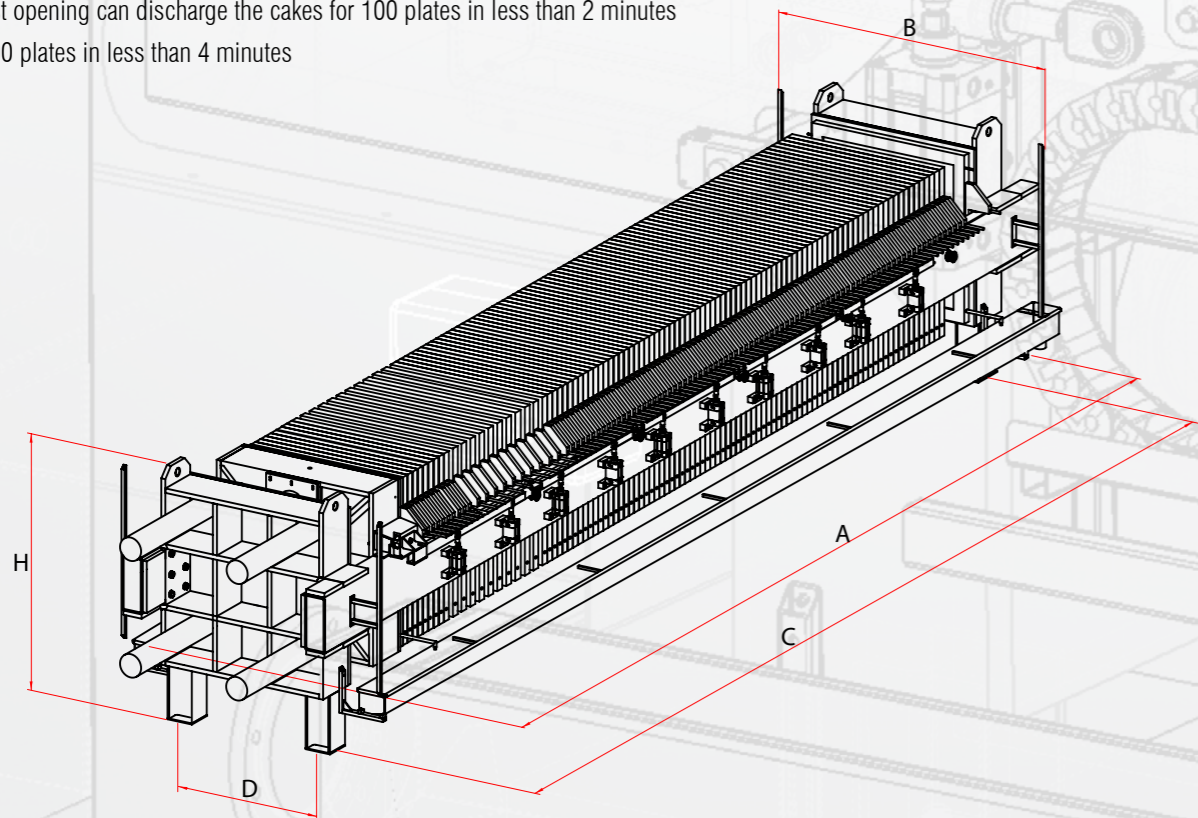

Specifications

Magnum model 2000x2000	A Length	B Width	C Foot Footbase	D Foot Footbase	H Total Height	Dry Weight (Kg)	Chamber Volume (Liters)	Capacity per cycle (Liters)	m ³ /h (2 cycles)	Ton/h	m ³ /h (3 cycles)
2000/140 New TT	17.590	3.430	14.960	1.356	3.795	45.760	115	16.100,00	32,20	59,57	48,30
2000/200 TwinNewTT	22.820	3.430	20.200	1.356	3.795	55.640	115	23.000,00	46,00	85,10	69,00

ACCESSORIES

CLOTH AND PLATE WASHING

Cloth and plate high pressure washing system. The washing sequence is the same as the filtering one with clean water replacing mud. The result is cleaned cloths, plates, plate conduit, piping, mud pump. Besides, the system washes 10 plates at a time to guarantee a high quality result in a very short time.

CORE BLOW

Plate conduit and pipe cleaning system through a compressed air flow. A valve system excludes the mud pump during the air blowing sequence, avoiding damage to the pump itself.

DRIP TRAY

Water drip collecting system. During the filtration process, a small quantity of water might drip off the plates on mud cakes. To avoid that a tray system covers the discharge hole below the filter press during the process, it will reopen in the cake discharge phase. The system can be pneumatic or mechanic.

MEMBRANE PLATES

An additional squeezing system to further lower the residual humidity in the cakes. The membrane plates can reduce the chamber volume by pumping water in their special dead-air-space. This variation, together with the HPT MATEC High Pressure Pump, grants a lower residual humidity than standard plates.

MUD CAKE WASHING

Close circuit system for special mud with chemicals. It usually works together with the membrane plate system, allowing a clean water flow inside the plate chambers before cakes are discharged. This process rinses the cakes, to lower chemicals' level under the "special mud" threshold.

All the MATEC filter presses can be set up on different types of support: steel or concrete ones, and metal reinforced masonries. They can be built together with protection structures, such as canopies or insulated boxes, and ladders or stairs.



PROJECT
Rhino Kerco - Kentucky

“Big projects, turnkey engineering plants for works up to 200 tph.”

PROJECT
Preferred Sand - Wisconsin

“More than 500 installations all over the world in the Aggregate sector.”



PROJECT
Sunrock - North Carolina



matec[®]
machinery technology

PROJECT
Addwest - Arizona

*“Matec provides turnkey High-Tech
and easy-to-manage solutions.”*

MATEC[®]
machiner technology

PROJECT
Samuel Engineering - Utah

“Matec filter presses can handle all capacities and projects up to 1000 tons per hours.”

DECANTER SILOS

Matec produces purification plants for many different industries, for a perfect clarification of wastewater. Decanters are available in two versions:

Vertical decanters

Based on the principles of static decantation and natural precipitation of suspended solid particles. They speed up the clarification process through perfectly-sized silos, with a thrust cone and a water column which presses the sludge, and the use of an appropriate polyelectrolyte (floculant). Matec offers the quickest clarification process for any type of wastewater.

Horizontal decanters (scraper bridge)

Ideal for large water flow rates, they have a limited height and are provided with an upper sludge thickening system. They are operated by a scraper-bridge, which pushes the sludge that sinks to the bottom before being pushed out. The discharging is an automatic operation adjusted to the bridge effort. The sludge thus condensed can be disposed of into artificial lakes, quickly filtered by the filter press system.

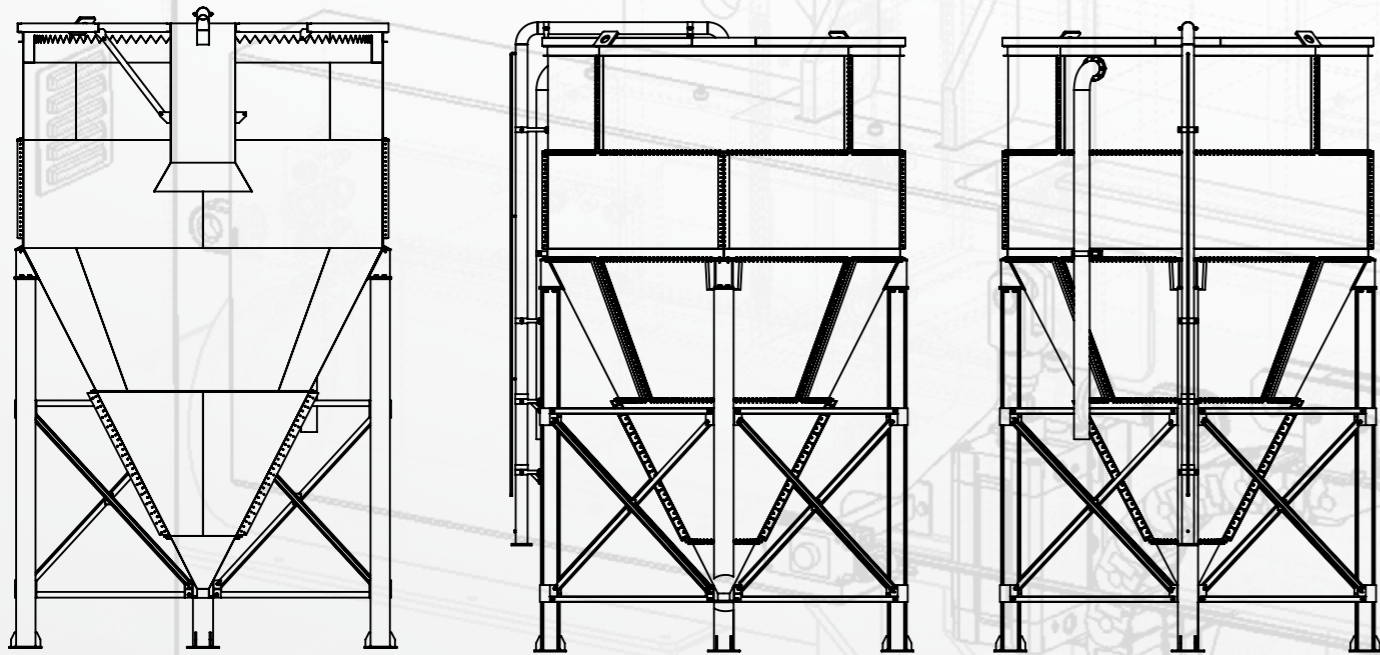

Specifications

Model	Capacity / t	Purified lt / min
SILOS INOX Ø 1.500 HF 1.500 HC 1.500	3.000	150
SILOS INOX Ø 1.500 HF 2.000 HC 2.000	4.600	200
SILOS INOX Ø 2.000 HF 2.000 HC 2.000	8.500	350
SILOS INOX Ø 2.200 HF 2.000 HC 2.000	10.000	400
SILOS INOX Ø 2.300 HF 2.500 HC 2.500	15.000	600
SILOS INOX Ø 2.500 HF 3.000 HC 3.000	20.000	800
SILOS INOX Ø 2.500 HF 4.000 HC 4.000	25.000	1.000
SILOS INOX Ø 3.000 HF 3.000 HC 3.500	30.000	1.200
SILOS INOX Ø 3.000 HF 4.000 HC 3.500	35.000	1.500
SILOS INOX Ø 3.500 HF 3.000 HC 3.500	40.000	1.700
SILOS INOX Ø 3.500 HF 3.500 HC 3.500	45.000	1.800
SILOS INOX Ø 3.700 HF 3.500 HC 3.500	50.000	2.000
SILOS INOX Ø 3.700 HF 4.000 HC 4.000	55.000	2.200
SILOS INOX Ø 4.000 HF 4.500 HC 4.000	75.000	3.000
SILOS INOX Ø 4.500 HF 4.500 HC 4.450	100.000	4.000
SILOS INOX Ø 5.800 HF 5.500 HC 5.000	180.000	7.000
DECANTER DIAM. 10	470.000	9.000
DECANTER DIAM. 13	600.000	10.000

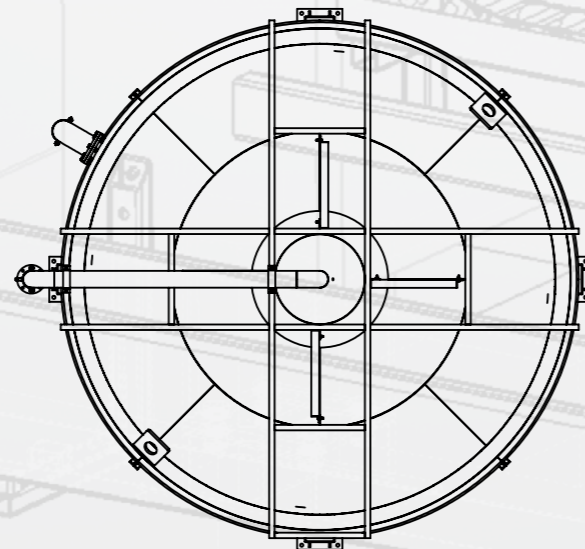

ma *tec*®
machinery technology

PROJECT
Metz - France



TECHNICAL Technical Support

Thanks to our highly skilled engineers, our global supplying/dealing network and our factory service personnel we can guarantee you an extensive range of services whenever you require them. Whatever business is yours it is important to us.

Matec provides all supplying/dealing service staff with a comprehensive training program. Our staff is equipped with the correct skills, exhaustive knowledge, methods and practices to support with pre-sales and after-sales service.

QUALITY Quality & Warranty

Matec equipment is rigorously tested, with high quality standards set for each step of the manufacturing process from design to distribution. Thus we can guarantee high quality and reliability.

If you experience problems with our equipments, your local supplier can access the online warranty system to solve the problem as soon as possible. Your feedback will be also incorporated into our R&D program to continue the development of our products.

24 MONTHS Guarantee

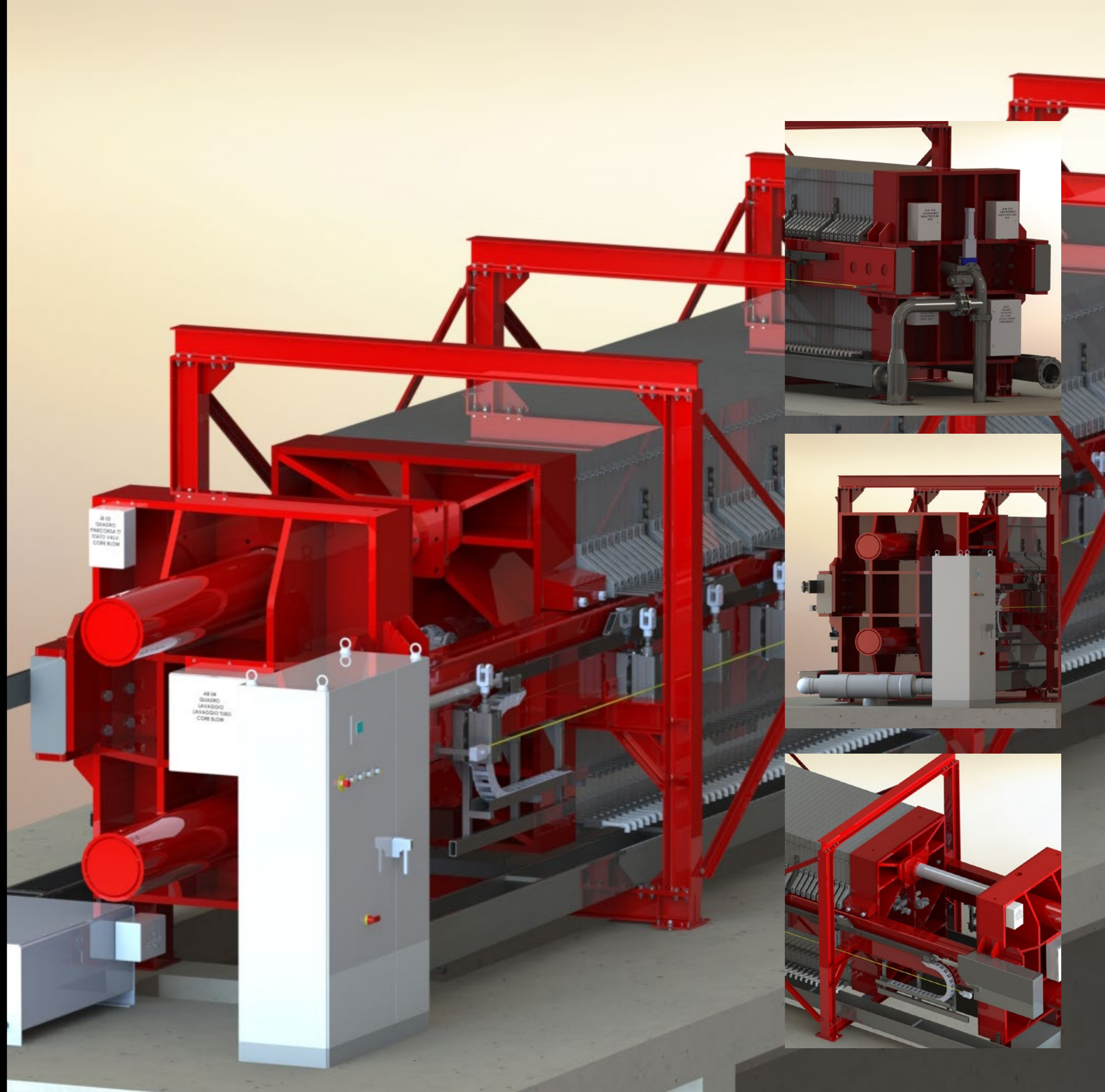



Matec Corporation S.r.l.

Via Aurelia Ovest, 383
54100 Massa (MS) Italy
Tel. +39.0585.831034
Fax. +39.0585.835598

www.mateccorporation.it



Matec America LLC

130 Plant Street
Walnut Cove, NC 27052
Tel. 270-841-9180
Fax. 336-591-9254

www.matecamerica.com



Matec S.r.l.

Via Aurelia Ovest, 383
54100 Massa (MS) Italy
Tel. +39.0585.831034
Fax. +39.0585.835598

www.matecitalia.com

