



Innovation at Work

EDGE TR516 TROMMEL SERIES



designengineeringinnovation



COMPACT, FLEXIBLE SCREENING



PRODUCT HIGHLIGHTS



KEY HIGHLIGHTS

FUEL CONSUMPTION 12-15 LTR/HR LITRES (3-4 USG) PER HOUR

Innovatively designed for fuel efficiency and low operating costs

1.54m (5') X 4.9m (16') long drum provides excellent screening results.

180° Radial Conveyor creates impressive stockpile volumes

Various aperture meshes, punch plate panels, fully welded punch plate drums with scrolls available.

Highly efficient hydraulic drive system with Intelligent load sensing.

Designed for easy transport from site to site, making it perfect for the rental market.

BEST OF BOTH WORLDS WITH THE 180° RADIAL FINES CONVEYOR



The EDGE Innovate TR516 trommel range has been designed for mid to large scale operations that may be constrained for space. Designed with durability in mind, the robust TR516 trommel range has proven capabilities in the recycling, composting and construction & demolition industries.

Thanks to design features such as the sixteen foot long barrel, variable speed control and a feed conveyor with intelligent load sensing controls; the EDGE 516 screening trommel is able to produce top-quality fine materials such as compost, gravel, sand and topsoil with ease. Various mesh sizes and barrel types are available for optimum screening performance.

By engineering a compact trommel with a radial discharge conveyor, the TR516 trommel has been able to maintain the benefits of a side conveyor product with all the advantages of an end conveyor offering.

DESIGN FEATURES

EDGE Innovate have worked tirelessly to ensure our products are of the highest quality. We only ever use parts and products that have been developed, tested and proven to provide optimal performance and reduce operating and maintenance costs. Every part is vital for uptime and performance.



HOPPER

- The TRM516 Hopper capacity ranges of up to 5m³ (6.5 yds³)
- Houses a 900mm (36") wide, variable speed feeder conveyor with load sensing functions to prevent drum overload.

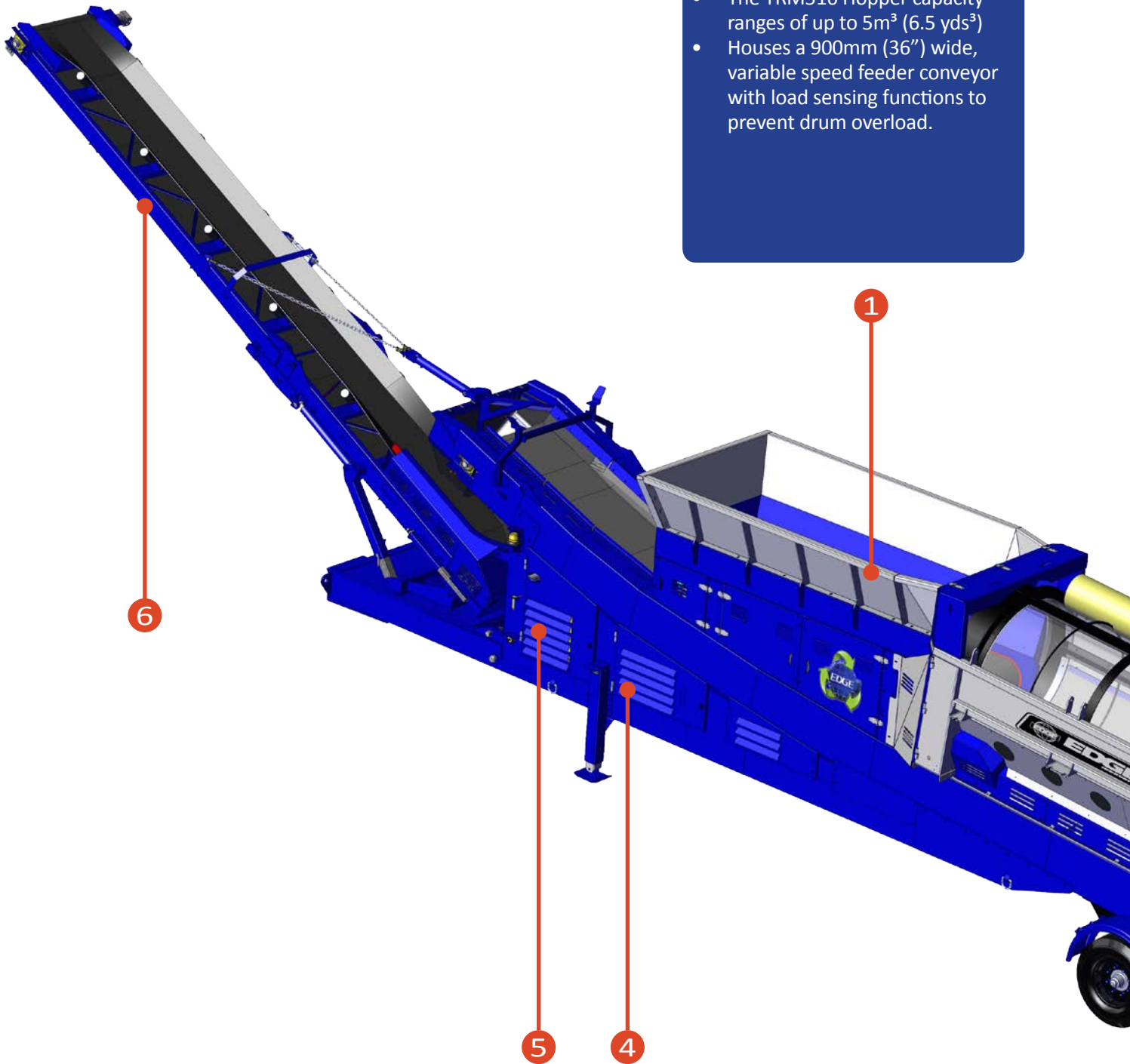

2



DRUM (BARREL)

- The 1.5m (5') X 4.9m (16') long drum with a built in screening angle of 5°.
- Driven via a direct 4 wheel drive system with a forward/reverse function and variable drum speed.
- Various aperture meshes, punch plate panels, fully welded punch plate drums with scrolls are available.

3



OVERSIZE CONVEYOR

- A heavy duty 900mm (36") wide conveyor providing a discharge height up to 3.2m (10'7").
- Impact bars as standard absorbs the impact of material, prolonging the lifetime of the belt.
- Hydraulic head fold function enables for quick transfer from transport to operational mode.

4



HYDRAULIC CONTROL SYSTEM

- Using pressure transducer technology the drum and feeder work in tandem.
- Pressure to drive the drum is constantly monitored, if becomes too high, the feeder will automatically reduce speed, if pressure continues, the feeder will slow down again to an eventual stop. Ensures against overload and asset damage.

2

3

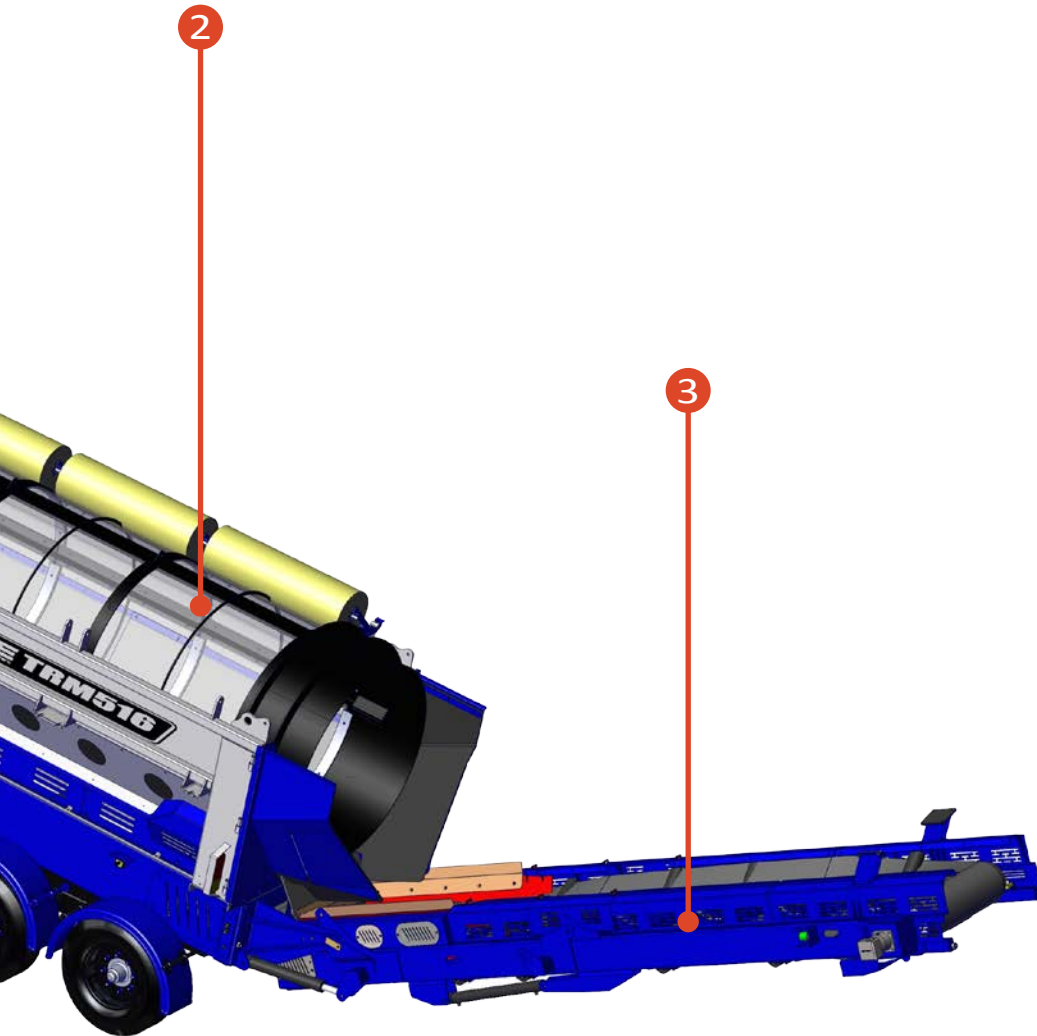

5



POWERUNIT

- Powered by a CAT C4.4 engine producing 74Kw (90HP) at 1900RPM.
- Encompasses a Hydraulic Tank with 500ltr (132USG) capacity and a Diesel Tank of 450ltr (118USG) capacity.

6



RADIAL FINES CONVEYOR

- The 180° radial fines conveyor consists of a 900mm (36") wide belt providing a discharge height of up to 5.3m (17'6").
- Hydraulic folding function enables for quick transfer from transport to operational mode.

STAGES OF SEPARATION

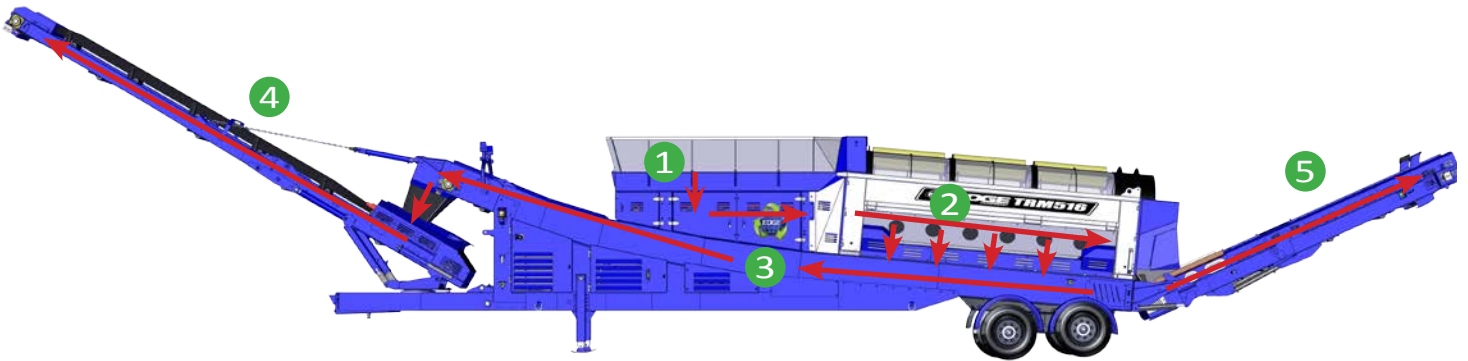

Feeder

- Intelligent hydraulic load sensing system to prevent overload. Feeder belt speed varies depending on drum pressure.
- Variable belt speed



Screening (Drum/barrel)

- Material is screened via the 1.5m (5') X 4.9m (16') long drum.
- Variable screening angle.
- Variable drum speed depending on application adjusted via hydraulic controls.



Collection Conveyor

- 1200mm (48") wide collection conveyor
- Carries screen material from drum to radial conveyor
- The combination of steep drum hopper sides and extremely wide collection conveyor prevent material bridging.



Radial Conveyor

- 180° Radial conveyor with hydraulic working angle adjustment.
- Discharge height of 5.3m (17'6").
- Working angle adjustment via hydraulic control valve.
- Remote radial left / right functionality available.



Oversize Conveyor

- Hydraulic telescopic oversize conveyor.
- Stockpiles oversize material from drum via it's 900mm (36") wide belt.
- Conical stockpile of 79m³ (103yrd³).



ADDITIONAL OPTIONS

TRM516 - Mobile Trommel



Mobile trommel is perfect for customers with multiple sites or for the rental market

TRS516 - Static Trommel



Option of hydraulic or direct electric. Suitable for indoor and outdoor applications

Diesel / Hydraulic



Cat4.4 74Kw (90HP)
Tier 3 / 3B & Tier 4 Final engines available

Drum Types

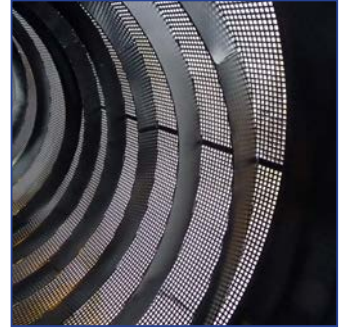

Various drum types, mesh apertures, punch plates and spiral drums available

Double Cleaning Brushes



Double hydraulic drum cleaning brushes available for tough screening tasks

Oversize conveyor



900mm (36") Oversize conveyor with a discharge height of 3.2m (10'7")

Radial Conveyor



180°, 900mm (36") Radial Fines conveyor with a hydraulic head fold

Twin Braking Axle



Twin braking axle required when discharge conveyors added

Overband Magnet



Overband magnet fitted to collection conveyor to extract ferrous metal

Hopper Extensions



Increase hopper capacity from 2m³ (2.6 yds²) - Std. to 5m³ (6.5 yds²)

Reversible Fan

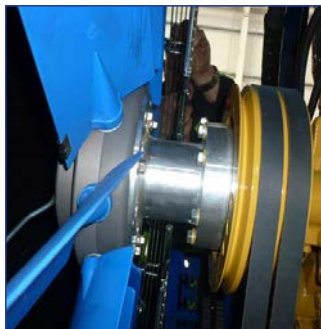

Reversible fan recommended for dusty applications such as wood chip



TECHNICAL SPECIFICATIONS

Machine	*Feed-In Height	Screening Area	Collection Conv. Discharge Height	Oversize Conv. Discharge Height	Fines Discharge Height
TRM516	3.4m (11'14)	18.6m ² (22.2 yds ²)	3.5m (11'6")	N/A	N/A
TRM516 w/conveyors	4m (13'1)	24.8m ³ (22.2 yds ²)	N/A	3.2m (10'7")	5.3m (17'6")

TRANSPORT DIMENSIONS

Machine	*Weight	Height	Length	Width
TRM516	15.5 Tonnes (17UST)	3.4m (11'14)	11.7m (38'4")	2.3m (7'7")
TRM516 w/conveyors	18.5 Tonnes (20.3UST)	4m (13'1")	15.5m (51")	2.3m (7'7")

OPERATING DIMENSIONS

Machine	Height	Length	Width
TRM516	4m (13'1")	12.6m (41'4")	2.3m (7'7")
TRM516 w/conveyors	5.3m (17'6")	23.4m (76'9")	2.3m (7'7")

TRM516 OPERATIONAL DIMENSIONS

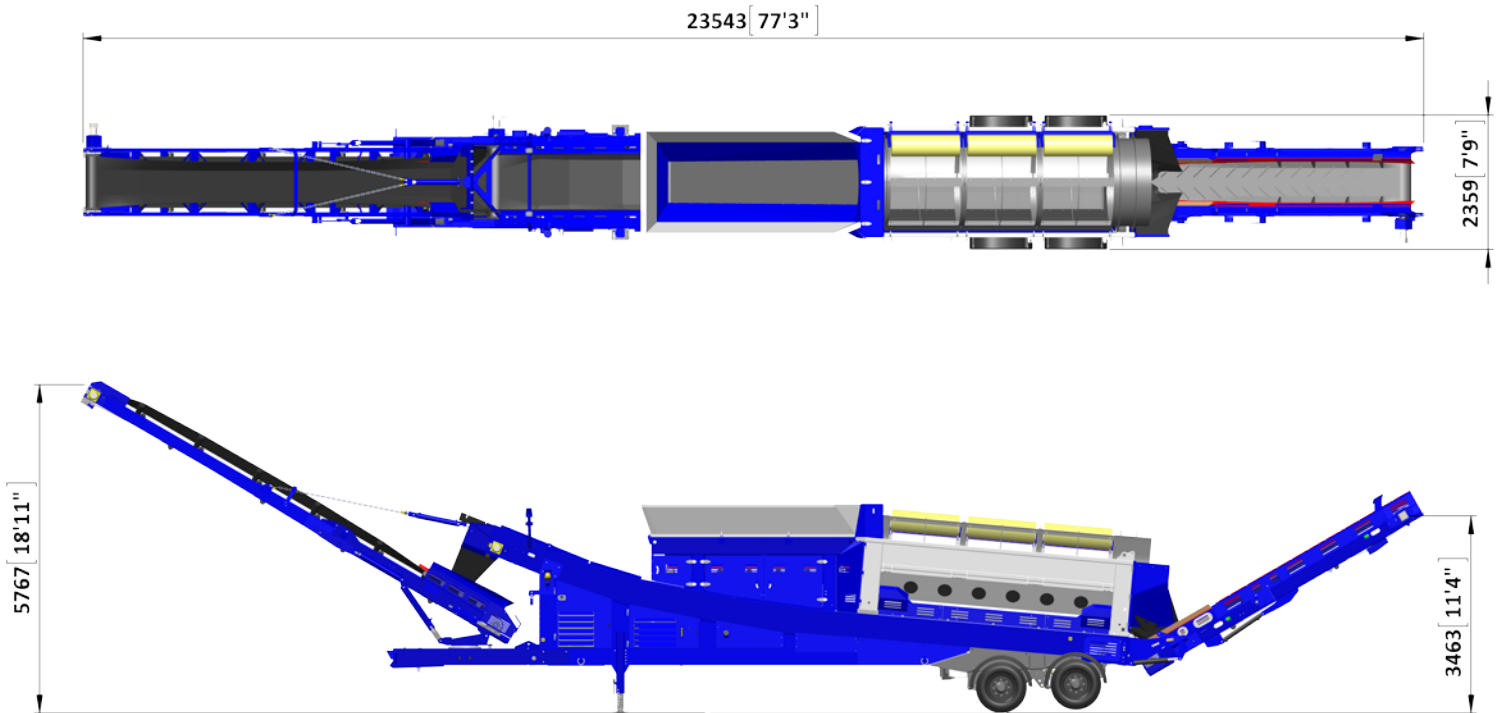

TRM516 OPERATIONAL DIMENSIONS (Single Axle)

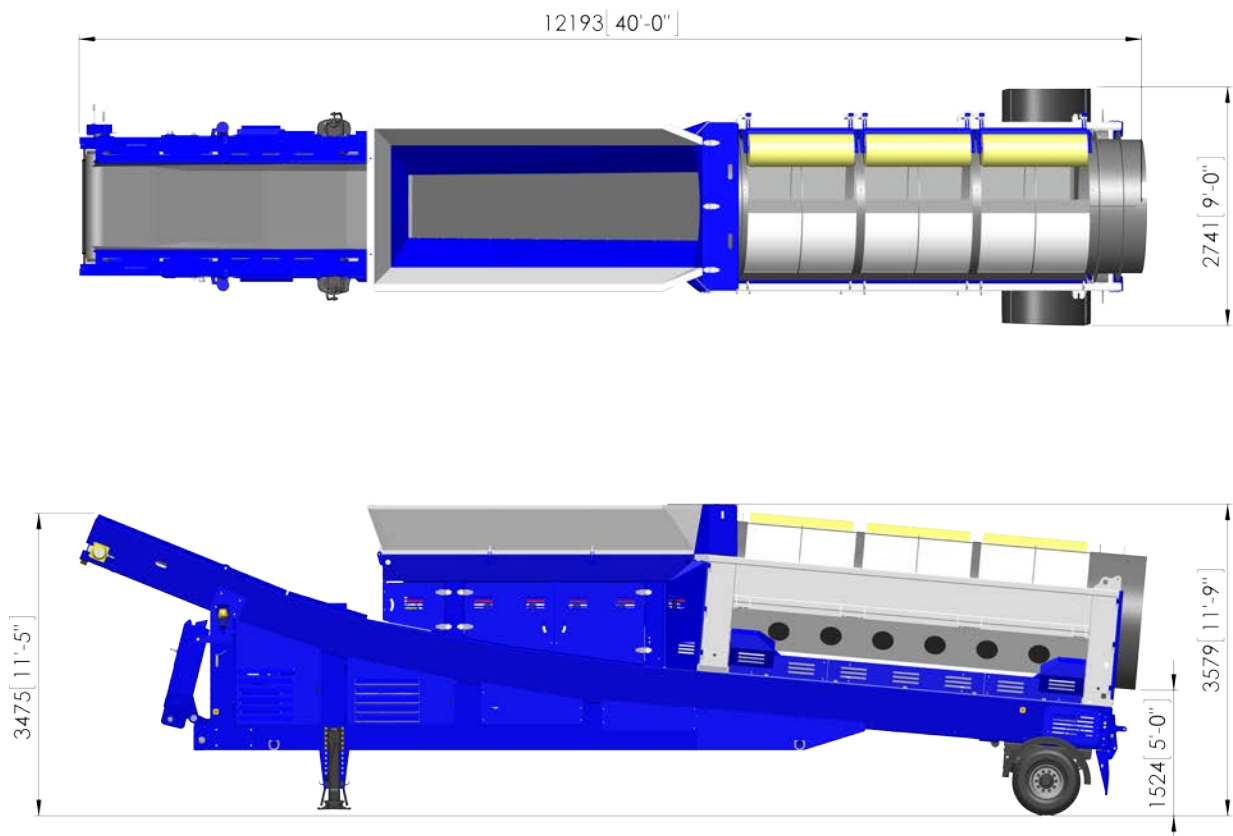

WE ARE HERE WHEN IT MATTERS MOST



PRODUCT AND TECHNICAL SUPPORT

With our ethos of “Innovation at Work”, EDGE not only persist in pushing the boundaries of design and manufacturing to produce hard working, quality machinery, we also bring that same ethos to our aftersales service in order to bring real benefits to customers right across the world. At EDGE we like to see the sales transaction as the start of a long-term partnership. Our goal is to offer the best customer support in the market for the lifetime of the unit. EDGE has reinvested and expanded our aftersales department in order to streamline and provide the customer support we believe our customers deserve.



Top Availability

Our Aftersales Support Team are readily available for all our customer needs. We are just a call away, all day, every day.



Top Speed

Express service parts available. No customer expects a long wait for replacement parts.



Top Priority

The market rightly demands quick up-time. To make sure of this, we work tirelessly with our international couriers.



Top Satisfaction

We track every despatch, keeping you informed all the way to ensure you are totally satisfied.

Welcome to our Comfort Zone...



Innovation at Work



**SPARE
AND WEAR
PARTS**

+44 (0)28 8774 0525

www.edgeinnovate.com/spares

aftersales@edgeinnovate.com

Edge Innovate's dedicated Aftersales, Spare Parts & Technical Support team, focus entirely on helping you the customer keep your machines running. We have a stock of £10m of spares in Ireland alone, along with other spare parts hubs in strategically positioned depots. Give us a call or email us today and use our stock and experience for your advantage!



Innovation at Work



Compact, Flexible Screening...

TR516 SERIES

TRACK / MOBILE RADIAL TROMMEL

+44 (0)28 8774 0525

www.edgeinnovate.com

info@edgeinnovate.com