

AggreSand 206



FEATURES

- 3 Aggregates, 2 Sand, 1 Machine
- Fully Modular
- Fully Automated
- Radio Controlled
- 5 x 40' Containers & 1 40' Flat Rack
- Pre Wired & Pre Plumbed
- 1 Day Set-Up
- 1 Electrical Connection Point
- 1 Water Connection Point

KEY FEATURES

- Fully Modular
- Fully Automated
- Radio Controlled
- Containerised Transport
- Pre Wired & Pre Plumbed
- Rapid Module set-up
- 1 Electrical Connection Point
- 1 Water Connection Point
- Curved chassis
- Quick set-up time
- Plug and play' electrical points
- Intelligent chassis design for access and wash down

APPLICATIONS

- Virgin Aggregate
- Manufactured Sand
- Sand & Gravel
- Crushed Rock
- Crusher dust
- Scalpings
- Iron ore
- Other mineral ores
- Construction & Demolition Waste Material

OPTIONS

- Single sand
- 2 deck



- Automated Radial Sand Stockpilers
- 350m³ (458yds³) Stockpile Per Conveyor
- 800m³ (1046yds³) Single Sand

- 4.8m x 1.8m (14' x 6') DW Screen
- Twin Sand Product up to 200tph
- High Frequency Dewatering Screen Delivering Superior Moisture Reduction
- Blending Chute

- 6m x 1.8m (20'x 6') 3 Deck/2 Deck
- Isolated Spraybars
- Polyurethane Decks
- 1 Or 2 Grade Rubberlined Catchbox
- Aggregate Blending Chute
- Service Accessible Rolling Chute

- Optional overband magnet for the removal of ferrous metals when operating in recycling applications

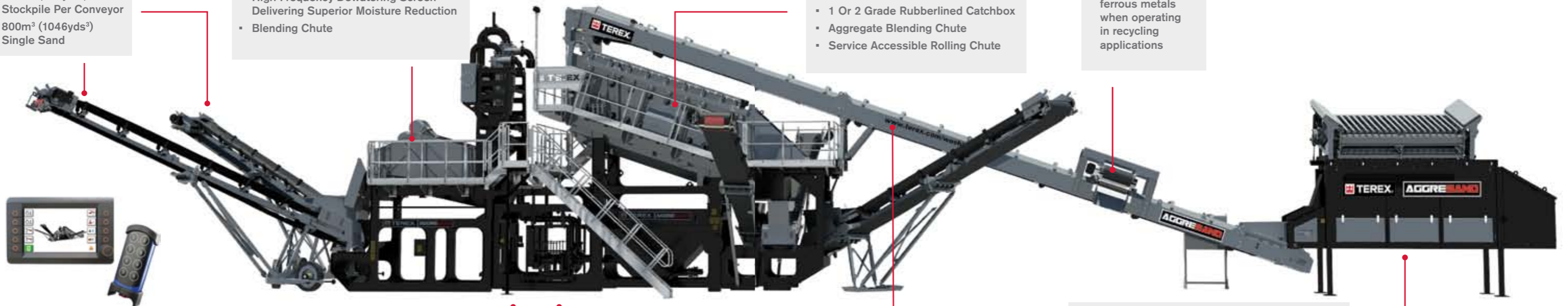

- Advanced Fully Automated Control System With Remote Communication And Radio Control

- Roll-In / Roll-Out Pumps For Easy Maintenance
- 1 or 2 Sand Production Up To 200tph

- 1050mm (41") Wide Belt
- Integrated Sealed Washbox
- Raisable Head Section For Screen Access





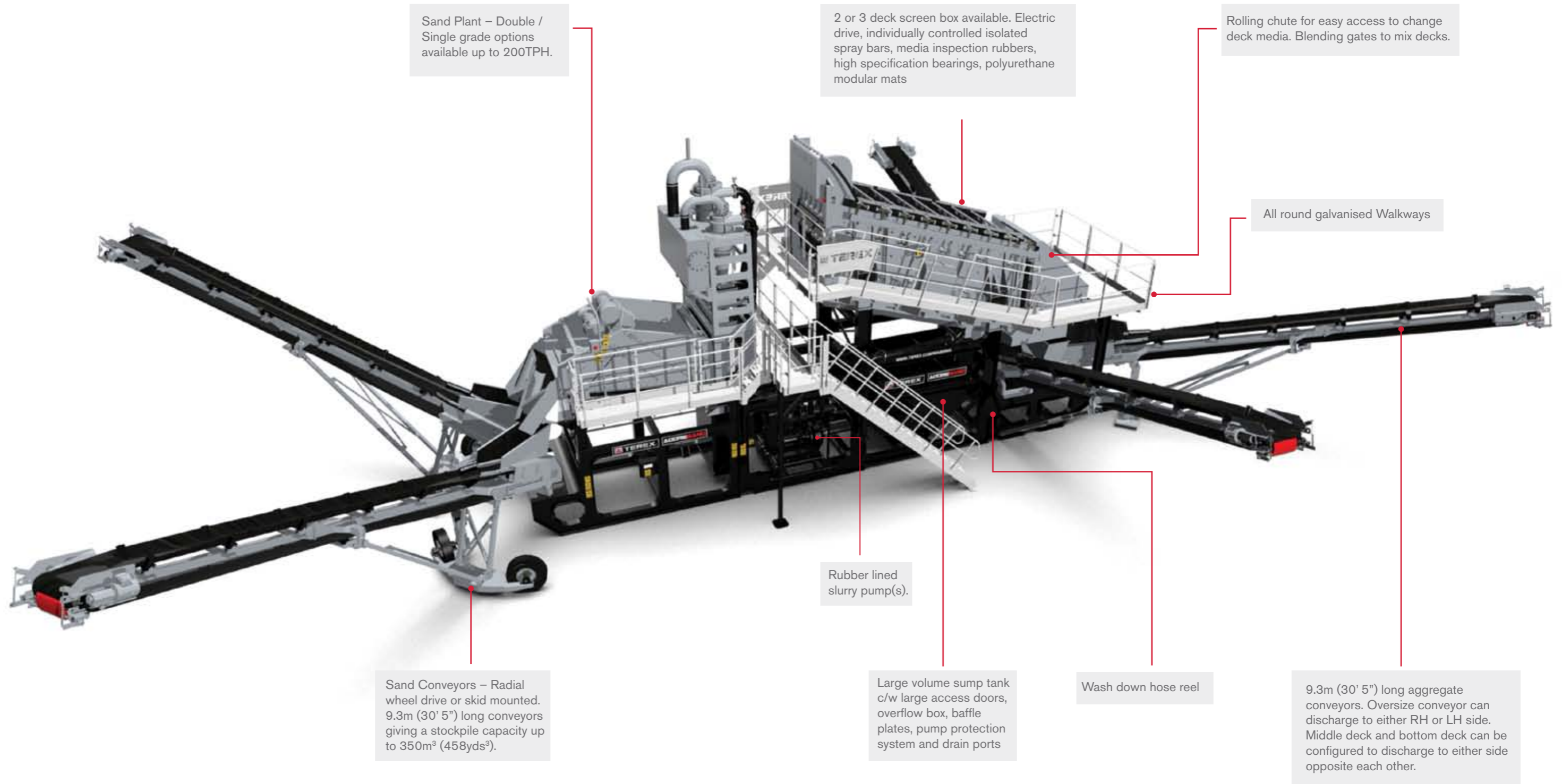

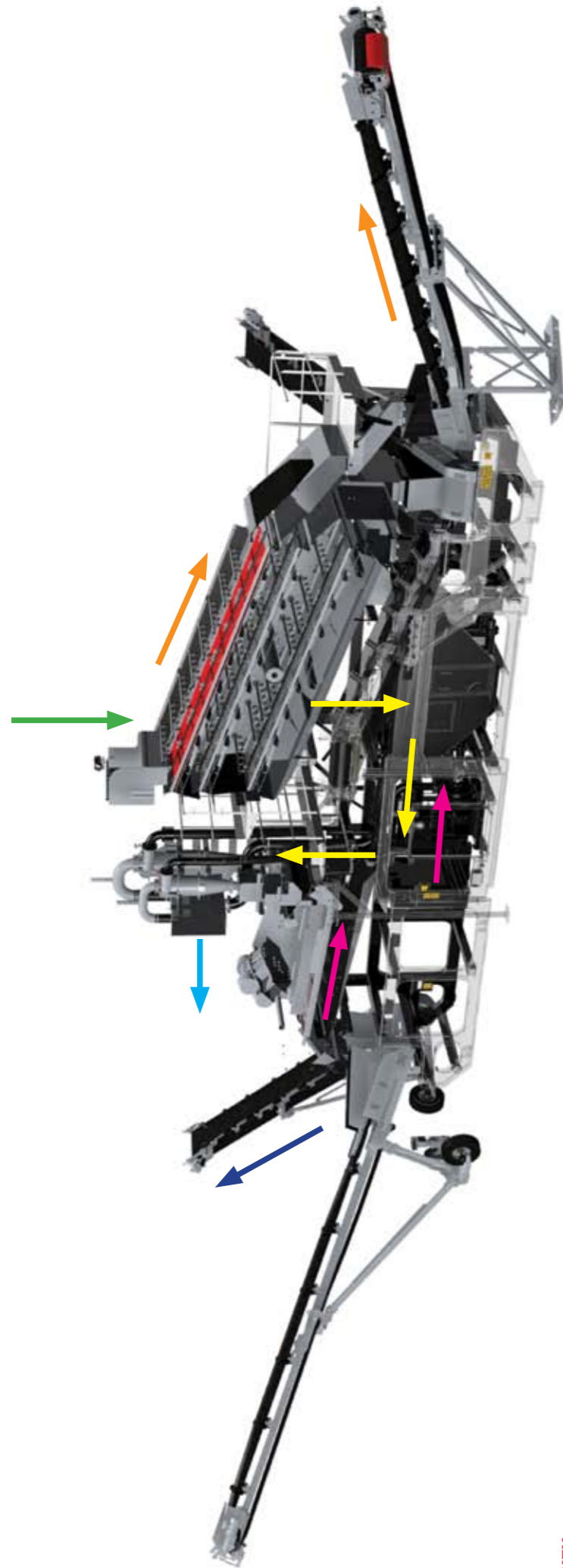
- Fully Modular 12m³ (16yds³) Capacity Hopper
- Radio Controlled Tipping Grid or Vibrating Grid
- Variable Speed Belt Feeder
- Vibrating Grid Option
- 37kw (50hp) electric hydraulic powerpack

AGGRESAND KEY FEATURES





KEY

-  Raw material fed from feed conveyor
-  Washed aggregate for stockpile
-  Slurry (sand & water)
-  Dewatered sand for stockpiling
-  Cyclone overflow to water treatment (water & silt)
-  Dewatering screen underflow back to sump tank

AGGREGATE SCREEN

- 20' x 6' (6m x 1.8m) Screen
- 2 or 3 deck screen box option
- Electrically driven
- Optimum 18 degree working angle
- Enclosed rubber lined wash box complete with independently controlled spray bar
- Independently controlled isolated spray bars: 10 top deck, 8 middle deck, 8 bottom deck, complete with fan tail plastic nozzles
- Mesh deck as standard, polyurethane modular decks as option
- Lined rolling chute arrangement complete with blending capabilities
- Rubber lined catch box (complete with 1/3-2/3 rubber lined division plate for dual sand models)
- Rubber lined discharge chutes
- HMI Pressure sensor on water manifold



SAND PLANT

- High frequency 4.3m x 1.8m (14' x 6') dewatering screen – dewatering up to 200TPH of sand
- Polyurethane modules and side protection bars
- Moulded central division plate (double grade only)
- Rubber lined cyclones
- Ceramic lined inlet bends
- Rubber lined underflow boxes - c/w quick release lid
- Rubber lined blending box - c/w quick release lid (double grade only)
- 5.5m (18') dirty water discharge height
- Spray bar in catch box
- Catch box for screen underflow
- Polyethylene wear lining in discharge chute
- Adjustable discharge blending chute – double grade only
- Pressure gauge to monitor cyclone inlet pressure



CENTRE CHASSIS

- Rubber lined slurry pump(s) situated upon roll out maintenance platforms
- Ceramic lined bends
- One point water feed
- Large volume sump tank
- Plant wash down hose on retractable reel (option)
- Split tank for double grade (double grade only)
- Self regulating sump tank
- Letterbox on divider plate to keep tank levels equal (double grade only)
- Overflow box
- Large inspection doors (both sides on double grade)
- Tank drain (both sides on double grade)
- Anti-turbulence baffle plates
- Replaceable rubber lined wear plates on feed area



AGGREGATE CONVEYORS

- Reconfigurable conveyors
- Plain 26" (660mm) wide belt
- 18 degree angle
- High quality PU scraper
- Direct drive electric gearbox
- 9.3m (30' 5") long
- 4.1m (13' 5") discharge height
- 3 deck oversize conveyor can discharge to right or left side

SAND CONVEYORS

- Rigid – folded for transport
- Radial – as standard
- Radial – wheel drive as standard
- Plain 26" (660mm) wide belt
- 20° angle
- Polyurethane tear drop scrapers standard
- Direct drive electric gearbox
- 9.3m (30' 5") long
- 4.9m (16' 1") discharge height



WALKWAYS

- Fully galvanised
- Walkway round both sides of machine
- Expanded metal walkway floors
- 600mm (24") wide
- Full 360° access

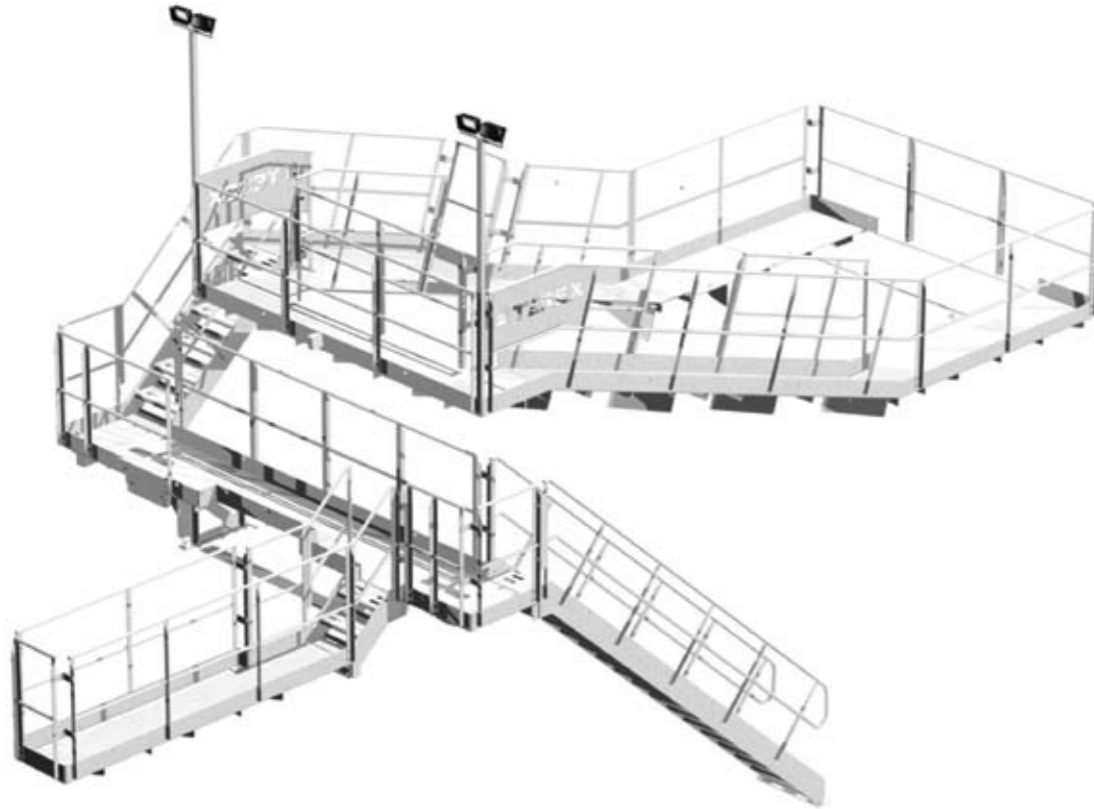

CONTROL SYSTEM

- Robust full color graphic HMI (Human Machine Interface)
- Automated Start / Stop sequence of all plant items
- Automated sequence shutdown on fault detection
- On-screen display of all key Parameters inc:
 - Inlet water Flow
 - Cyclone pressure
 - Hydraulic oil level and temperature
- Radio control of
 - Plant Start / Stop
 - Feeder Start / Stop
 - Sand Conveyor Radial Drive
 - Tipping Grid Raise / Lower
 - Plant Lighting On / Off



OPTIONS

- Telemetry System with remote communication of all alarms and status such as TPH via text message and / or email (can be tailored to exact requirements)
- All motors load currents and voltages

FEED SYSTEM (OPTIONAL)

HOPPER

Capacity	12m ³	(16yds ³)
Grid Spacing	100mm	(4")

2 DECK VIBRATING GRID

Working angle	10-20°
Tipping angle	45° max
Motor	59cc/rev

POWERPACK

Option 1 power requirements (Feeder only)	37kW	(50hp)
Option 2 power requirements (Feeder/Radio tipping)	37kW	(50hp)
Option 3 power requirements (Live head/Feeder/Radio tipping)	37kW	(50hp)

FEED CONVEYOR

Length	22.7m	(74' x 9")
Belt	1050mm	(41")
POWER REQUIRED	11Kw	(15hp)

TECHNICAL INFORMATION

SCREEN BOX	2 SAND, 2 AGG	2 SAND, 3 AGG	1 SAND, 2 AGG	1 SAND, 3 AGG
Screening Area	6m x 1.8m (20' x 6')	6m x 1.8m (20' x 6')	6m x 1.8m (20' x 6')	6m x 1.8m (20' x 6')
Number of decks	2	3	2	3
Power required	22kW (30hp)	22kW (30hp)	22kW (30hp)	22kW (30hp)
Mounting	Spring	Spring	Spring	Spring
Screen Bearings	2 bearing	2 bearing	2 bearing	2 bearing
Max spraybar water throughput @ 2 bar	250m ³ /hr (325yrd ³ /hr)	380m ³ /hr (390yrd ³ /hr)	250m ³ /hr (325yrd ³ /hr)	380m ³ /hr (390yrd ³ /hr)

SAND PLANT

Dewatering Screen	4.3m x 1.8m (14' x 6')	4.3m x 1.8m (14' x 6')	4.3m x 1.8m (14' x 6')	4.3m x 1.8m (14' x 6')
Dewatering Screen Power Required	13kW (16hp)	13kW (16hp)	13kW (16hp)	13kW (16hp)
Fines Pump	200/150 22KkW (30hp)	200/150 22KkW (30hp)		
Coarse Pump	200/150 30KkW (40hp)	200/150 30KkW (40hp)	250/200 45KkW (58hp)	250/200 45KkW (58hp)

STOCKPILE CONVEYORS

Quantity	4	5	3	4
Length	9.3m (30' 5")	9.3m (30' 5")	9.3m (30' 5")	9.3m (30' 5")
Belt width	650mm (26")	650mm (26")	650mm (26")	650mm (26")
Belt type	650mm EP315 3 ply plain x 3+1.5 covers	650mm EP315 3 ply plain x 3+1.5 covers	650mm EP315 3 ply plain x 3+1.5 covers	650mm EP315 3 ply plain x 3+1.5 covers
Stockpile capacity - Sand	350m ³ (458yds ³) (per conveyor)	350m ³ (458yds ³) (per conveyor)	800m ³ (1046yds ³)	800m ³ (1046yds ³)
Stockpile capacity - Aggregate	100m ³ (131yds ³)	100m ³ (131yds ³)	100m ³ (131yds ³)	100m ³ (131yds ³)
Power Required	4kW (5hp) x 4	4kW (5hp) x 5	4kW (5hp) x 3	4kW (5hp) x 4
Wheel drive power requirements	0.37kW (0.5hp)	0.37kW (0.5hp)	0.37kW (0.5hp)	0.37kW (0.5hp)

POWER AND WATER REQUIREMENT

MAXIMUM POWER REQUIREMENT	152.74kW (198.5hp)	155.74kW (202.5hp)	140.37kW (182.5hp)	144.37kW (187.7hp)
AVERAGE WATER REQUIREMENT	235m ³ /hr (307yrd ³ /hr)	340m ³ /hr (445yrd ³ /hr)	235m ³ /hr (307yrd ³ /hr)	340m ³ /hr (445yrd ³ /hr)

DIMENSIONS

WORKING DIMENSIONS (WITHOUT FEED SYSTEM)

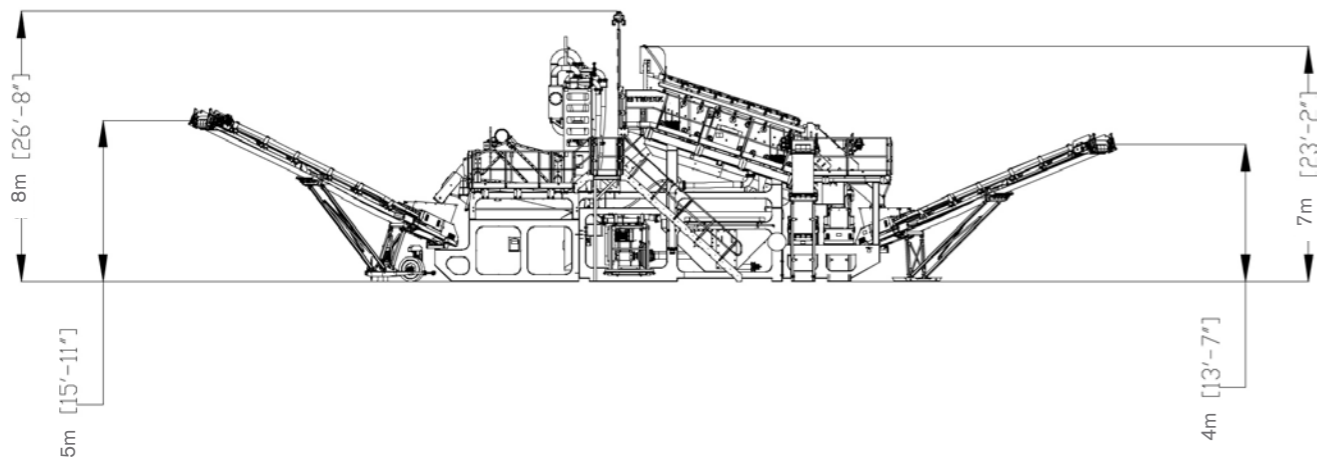
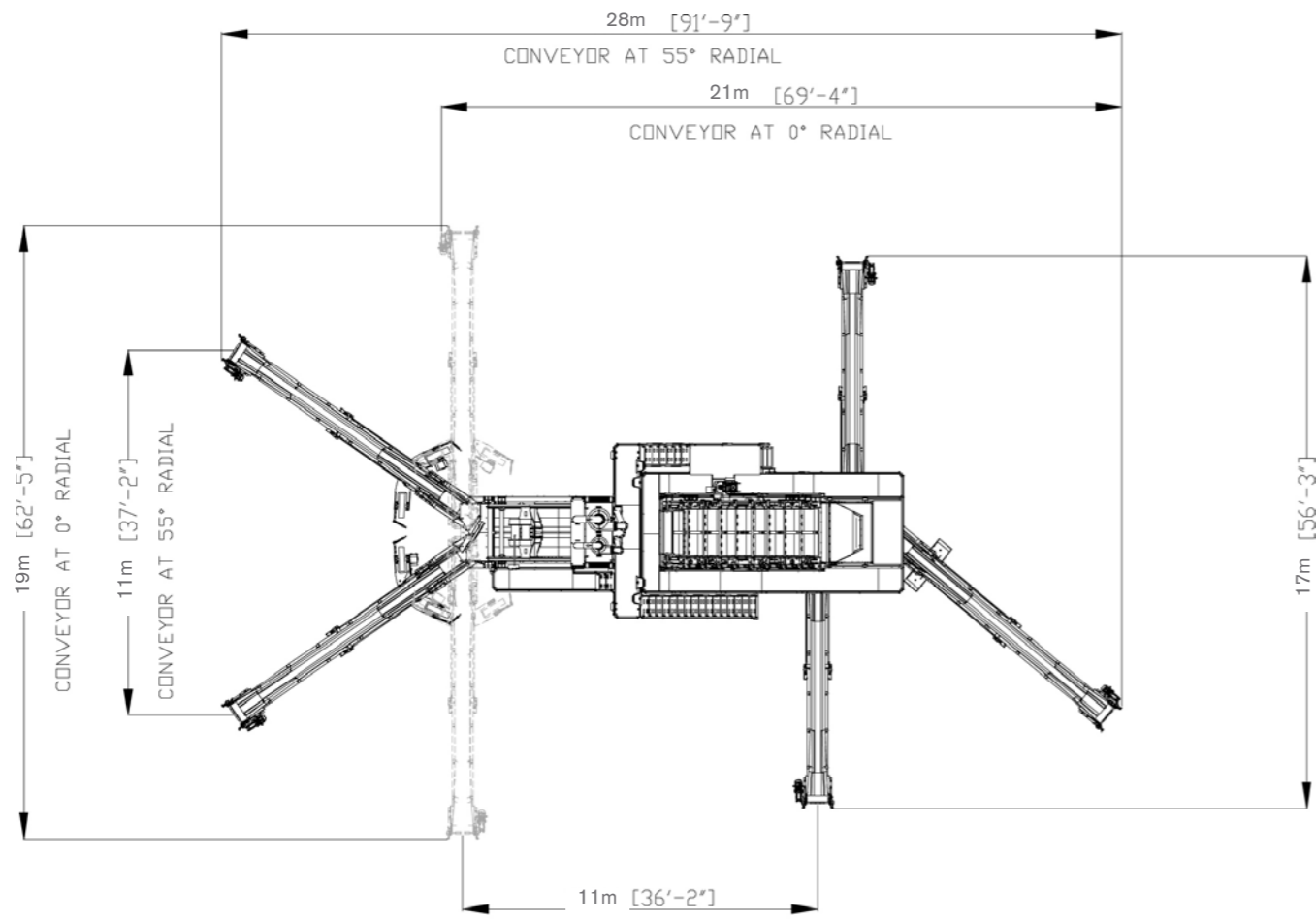

WORKING DIMENSIONS (WITH FEED SYSTEM)

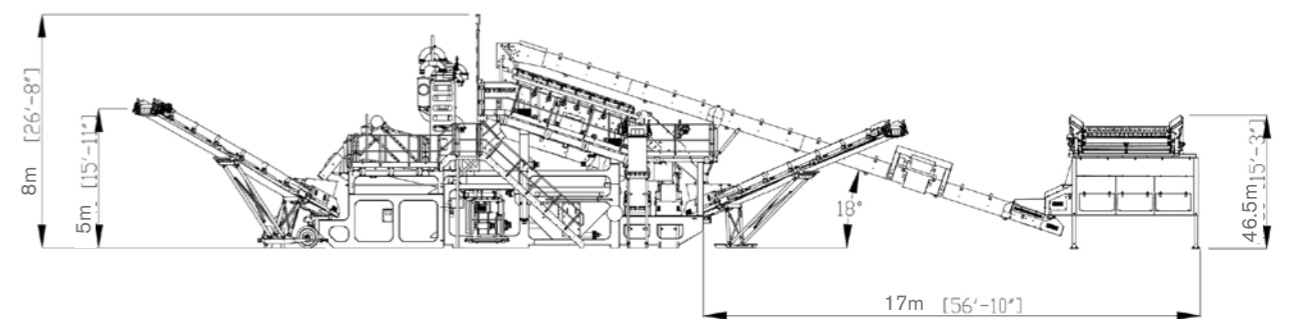
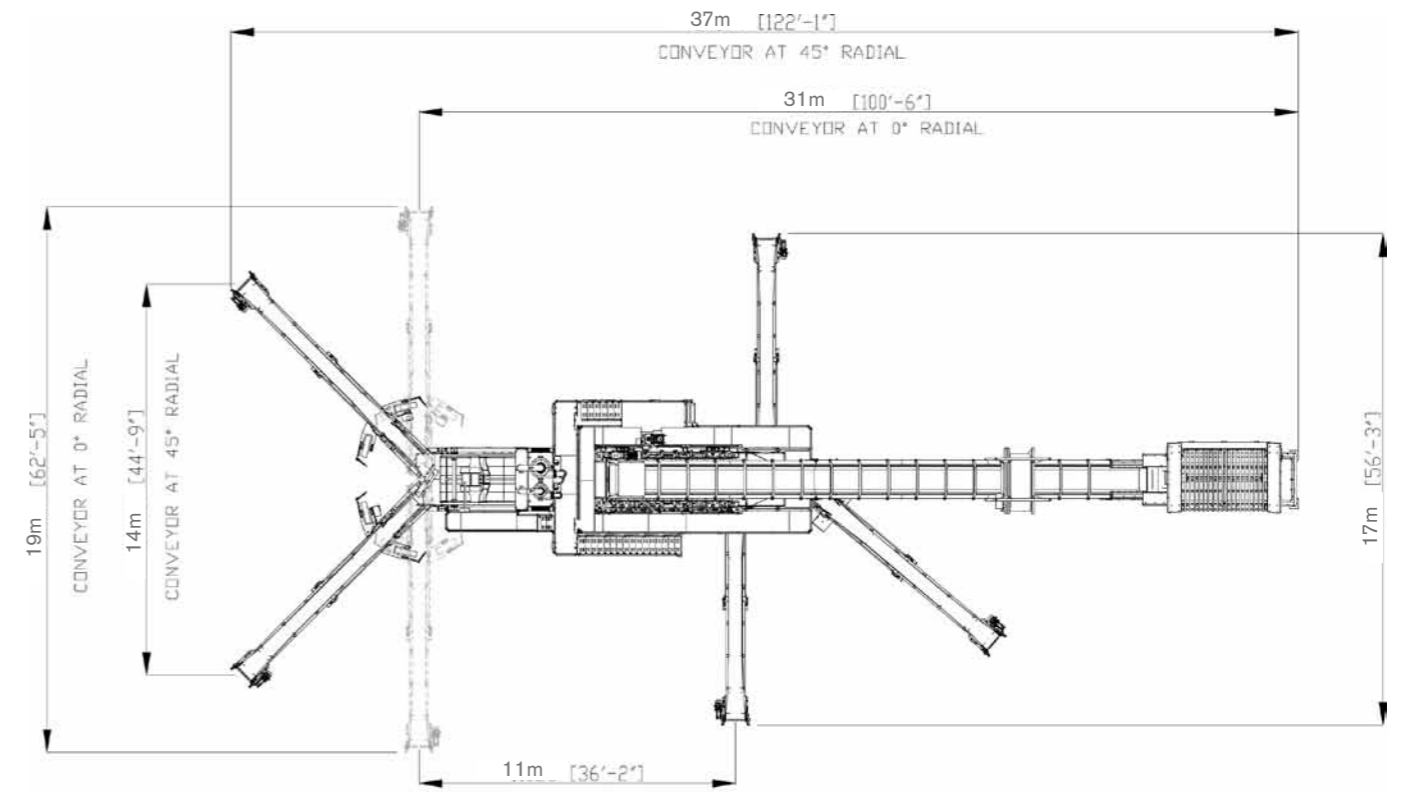

AGGRESAND PLINTH

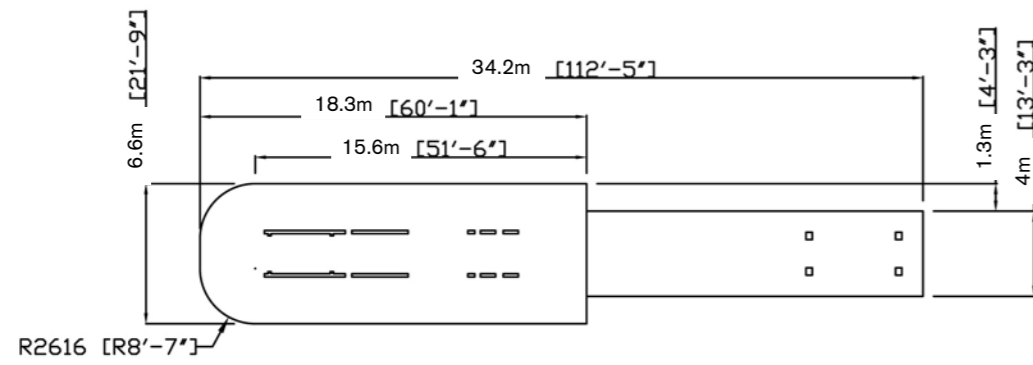
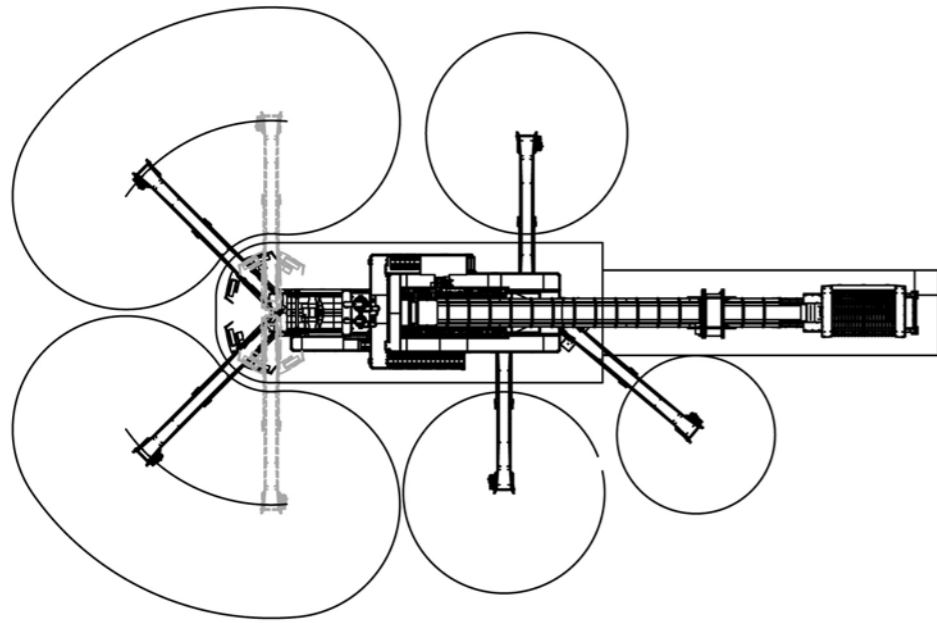

AGGRESAND FOOTPRINT

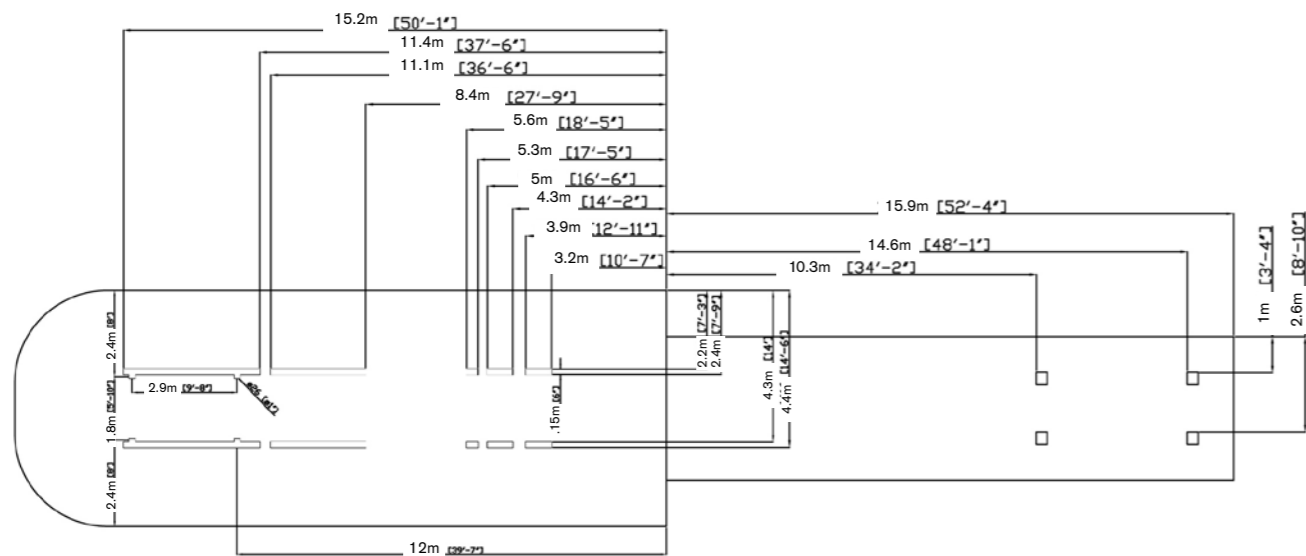

AGGRESAND

Static Weight of Machine on Foot Print (Empty)	40,500kg
Dynamic Weight of Machine on Foot Print (Full)	52,200kg ±802kg (Vertical) ±401kg (Horizontal)

TRANSPORT CONTAINERS

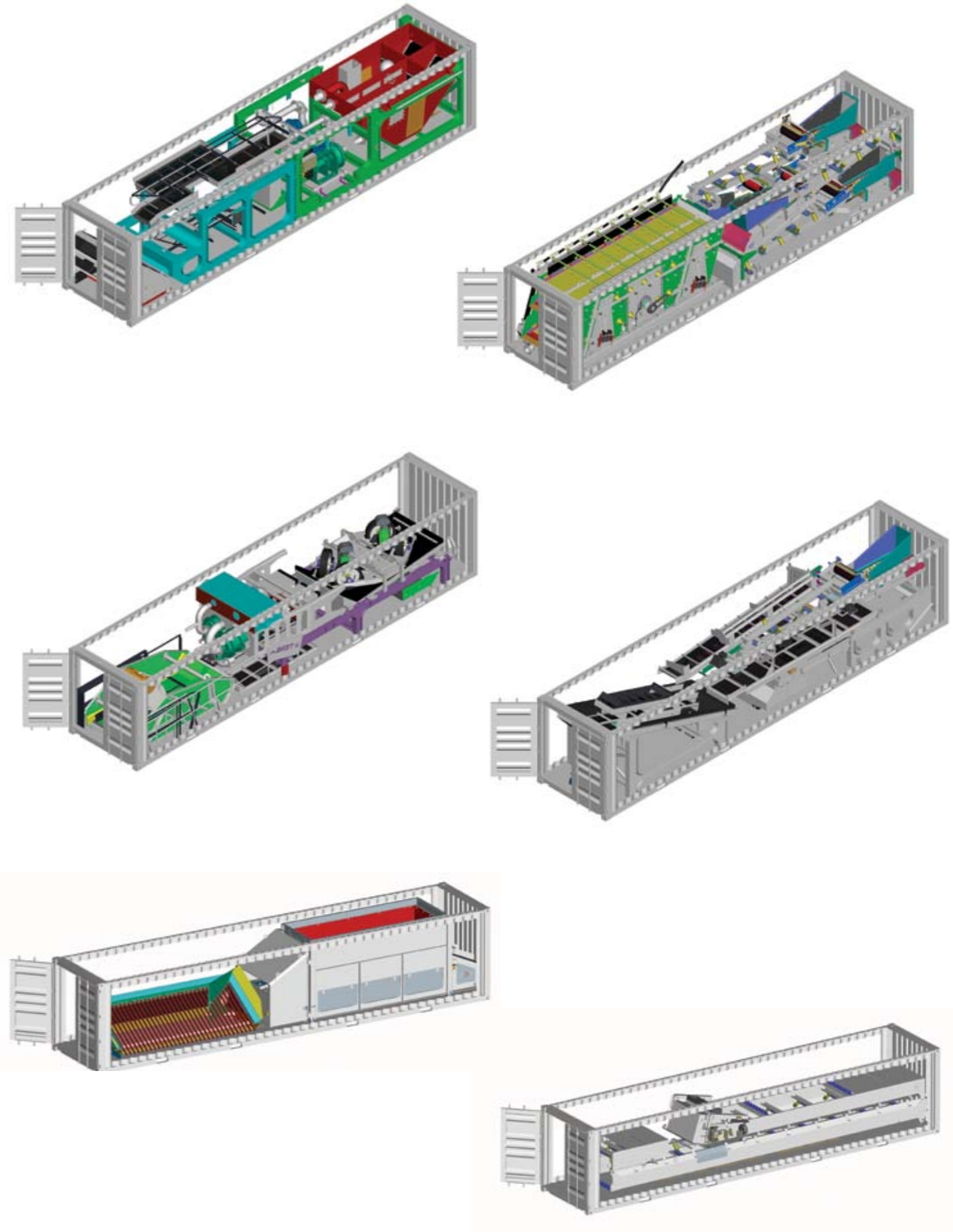



Aggresand 165, Ireland



Aggresand 165, High Capacity Sand Plant, USA



Aggregate Screen Fitted with Isolated Spraybars



Integral Aggregate Stockpiling Conveyors



3 Deck Aggregate Screen With Rolling Chute For Access



Radial Conveyors



Cutting Edge Control Panel



Centrifugal Pumps, Roll out for Service Access

TEREX WASHING SYSTEMS CONTACT DETAILS

Dungannon Site

200 Coalisland Road
Dungannon
Co. Tyrone
Northern Ireland
BT71 4DR

Tel: +44(0) 28 8771 8500

Email: TWS.sales@terex.com

www.terex.com/washing

You  Tube

Check out Terex Washing Systems videos
on YouTube: www.youtube.com/terexwashingsystems



www.facebook.com/TerexCorporation

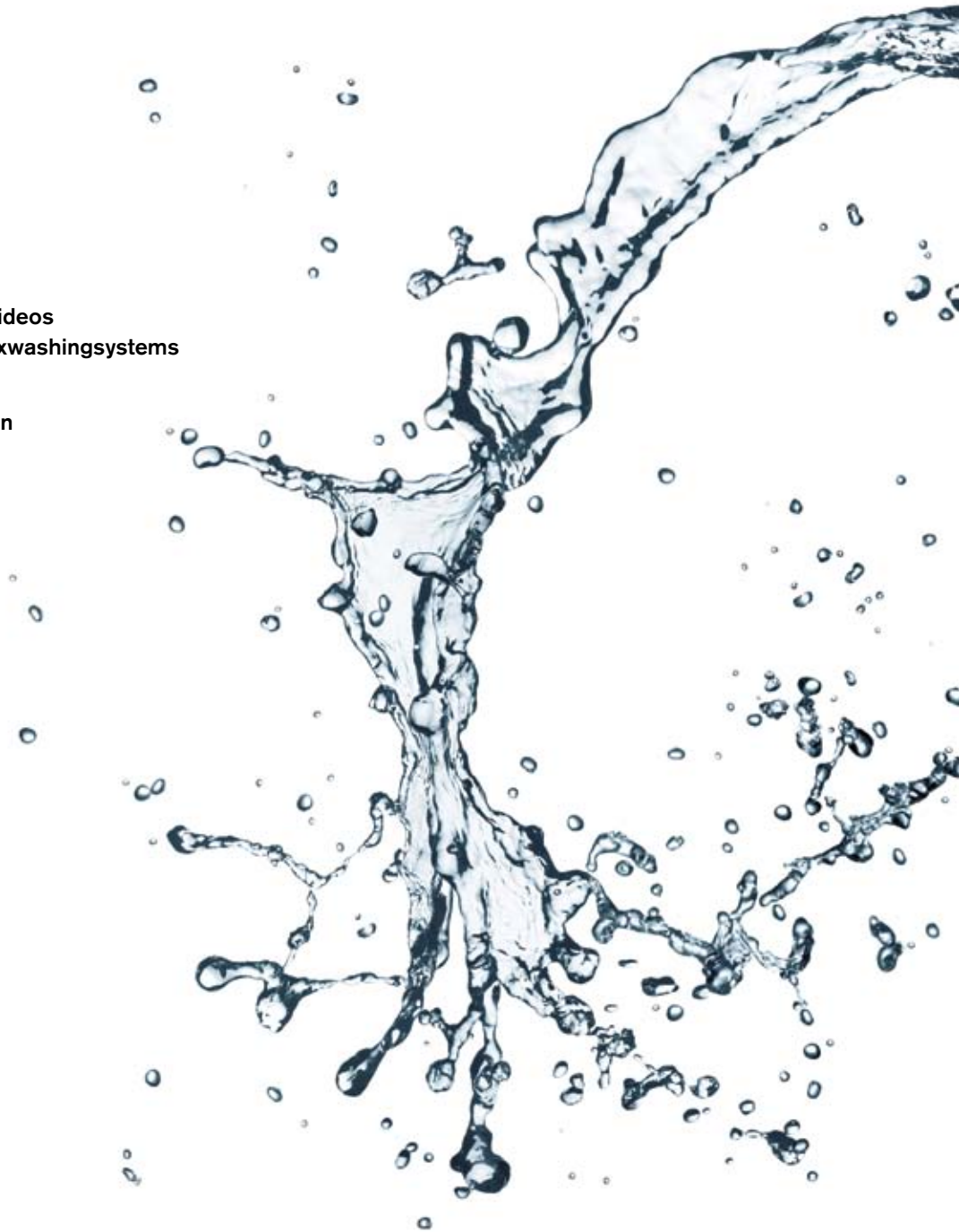

Effective Date: April 2013 Product specifications and prices are subject to change without notice or obligation. The photographs and/or drawings in this document are for illustrative purposes only. Refer to the appropriate Operator's Manual for instructions on the proper use of this equipment. Failure to follow the appropriate Operator's Manual when using our equipment or to otherwise act irresponsibly may result in serious injury or death. The only warranty applicable to our equipment is the standard written warranty applicable to the particular product and sale and Terex makes no other warranty, express or implied. Products and services listed may be trademarks, service marks, or trade names of Terex Corporation and/or its subsidiaries in the USA and other countries. All rights are reserved. Terex is a registered trademark of Terex Corporation in the USA and many other countries. © 2010 Terex Corporation.



TEREX®

WORKS FOR YOU.™