

UNBEATABLE POWER UNMATCHABLE COMPACTNESS

RM CRUSHERS



RM GROUP FACTS



"It all started with a vision: we wanted to make it possible to recycle C&D waste materials on site. This innovative idea became an international success, and we are now the world leader in compact crushing. This folder provides you with an overview of our crushers, which make it possible to process C&D waste materials and natural rock on site profitably. Please contact us - we look forward to talking to you!"

Gerald Hanisch
Gerald Hanisch
Founder and Managing Director
RUBBLE MASTER HMH GmbH

WELCOME! TO OUR WORLD

From pioneer of on-site recycling to world leader of compact crushing! We can rely on our proven assets as we move from strength to strength. With highly innovative products, strong service and customer orientation and the best team in the industry, we are always one step ahead.



EVERY ELEMENT A HIGHLIGHT

Innovation in every detail - goes without saying in the world of the market leader for mobile crushers. The innovative refeeding system, the compact design for straightforward transport and the smart GO! system are just some of the highlights that have made RM crushers the benchmark in recycling and processing natural rock.



Closed material circuit - mesh screen with integrated refeeding belt and optional wind sifter. Graded final aggregate in a single pass



The most versatile crushing box in the industry



Optimised material flow from the vibro-channel to the main discharge belt



Patented innovation: RM Active Grid® - up to 30% higher throughput



Drive and crush at the same time



Highest performance - lowest emissions
Innovative RM drive technology for every application



Rapid adjustment of crusher settings



360° ground-based service

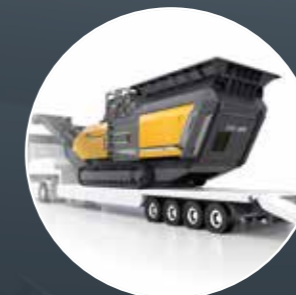

Compact design for quick and easy transport



NEXT level electrification - machine2machine communication

RM GO! PRINCIPLE IT'S ALL ABOUT YOUR ADVANTAGE

The unique, innovative GO! principle stands for: simplicity and efficiency in every move, in every step. Following the principle - Buy. Start. Earn money. - your RM crusher works for your success from the very first hour and opens up new perspectives for your business.



BUY

The RM dealerships are the best trained professionals at your side. They make sure that you find the best crusher for your contracts and projects.



START

GO! means: set up, get going. The compact dimensions facilitate straightforward, rapid transport to locations that are normally difficult to access.



EARN MONEY

Creating value from the first minute instead of having to pay for transport, landfill and procurement costs. You start earning money from the word go - efficiently and profitably.

The RM GO! principle has been extended even further as part of the latest RM NEXT concept. There are numerous new features to enhance intuitive operation, the safety of the machine and accessibility.



RM 60

THE PERFECT CRUSHER FOR NEWCOMERS TO RECYCLING



THROUGHPUT
80 T/H

INLET OPENING	640 x 550 mm
DRIVE SYSTEM	JOHN DEERE MOTOR
TRANSPORT DIMENSIONS	6.320 x 2.020 x 2.690 mm



RM 70GO! 2.0

WHISPER QUIET AND LOW ON EMISSIONS



THROUGHPUT
150 T/H

INLET OPENING	760 x 600 mm
DRIVE SYSTEM	JOHN DEERE MOTOR
SCREEN SURFACE	1,9 m ²
TRANSPORT DIMENSIONS (INCL. MS)	13.300 x 2.360 x 3.100 mm

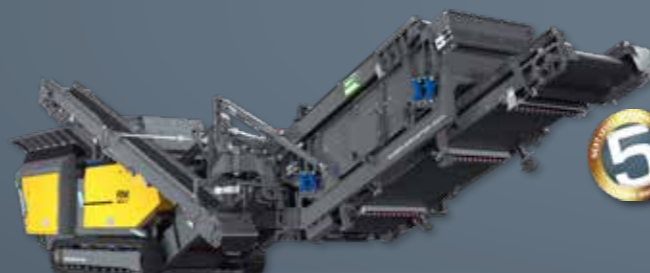

RM 120X

BEYOND KNOWN STANDARDS



THROUGHPUT
350 T/H

INLET OPENING	1.160 x 820 mm
DRIVE SYSTEM	JOHN DEERE MOTOR
SCREEN SURFACE	5,5 m ²
TRANSPORT DIMENSIONS (INCL. MS)	16.440 x 3.000 x 3.200 mm



RM V550GO!

MAXIMUM FLEXIBILITY IN PROCESSING ROCK



THROUGHPUT
200 T/H

INLET OPENING	950 x 480 mm
DRIVE SYSTEM	JOHN DEERE MOTOR
SCREEN SURFACE	3,6 m ²
TRANSPORT DIMENSIONS (INCL. MS)	16.300 X 3.000 X 3.200 mm



RM 90GO!

THE MOBILE SOLUTION FROM INNER CITIES TO ALPINE TERRAIN



THROUGHPUT
200 T/H

INLET OPENING	860 x 650 mm
DRIVE SYSTEM	JOHN DEERE MOTOR
SCREEN SURFACE	2,2 m ²
TRANSPORT DIMENSIONS (INCL. MS)	13.470 X 2.550 X 3.050 mm



RM 100GO!

THE HIGH-PERFORMANCE CRUSHER WITH LOW OPERATING COSTS



THROUGHPUT
250 T/H

INLET OPENING	950 x 700 mm
DRIVE SYSTEM	JOHN DEERE MOTOR
SCREEN SURFACE	3,5 m ²
TRANSPORT DIMENSIONS (INCL. MS)	14.700 X 2.860 X 3.155 mm

RM 60

THE SMART PROBLEM SOLVER

Straightforward, versatile, efficient: the most compact of the RM crushers can be transported using a hook lift and does not need a special transport permit; ready for action within the shortest time.

100 % emission-free with electric drive



“THE RM 60 IS PERFECTLY DESIGNED”

The RM 60 is perfectly designed, easy to operate and productive. The low operating costs and the high quality of the final aggregate for concrete and asphalt production are outstanding. The RM 60 is one of our most profitable machines because we save on landfill and material costs.

DJ Cavaliere, CEO, COR Equipment Sales, USA

TECHNICAL DATA

Throughput	up to 80 t/h, depending on material
Feed material size	up to a diameter of 500 mm
Feed opening	640 x 550 mm
Crusher unit	RM crusher with 2 or 4 hammers Kinematics mechanically adjustable for primary or secondary crushing mode
Feed unit	feed hopper 1 m ³ the hopper is a solid, reinforced steel structure, loading height 1,930 mm Loading width 1,860 mm, conveyor hopper width 640 mm Feed Control System (automatic control generation) automatic load-dependent crusher feeding
Discharge belt	folding conveyor 650 mm wide, cranked mechanically into transport position, discharge height 1,940 mm
Transport system	hook unit on truck
Weight	12,000 kg



JOB STORIES

CRUSHER AND SCREEN START OPERATION IN MANILA

Philippine mining company starts processing limestone with RM

This RM customer was previously known primarily for mining nickel, and now they have expanded their business model with RM to include the mobile processing of limestone for cement production. Following training and start-up by the RM service technician and the traditional blessing ritual, the 12 tonne RM 60 plus RM CS 2500 screen has been in operation up to eight hours a day.



RM IS THE PIONEER IN ON-SITE C&D WASTE RECYCLING IN HAIFA

A new amphitheatre was built after demolishing the beach promenade – and a new branch of business was born

The company was contracted in 2010 to renovate the destroyed beach promenade in Haifa. The paving stones that were removed (0-200 mm) were not transported away, but instead were processed on-site to form 0-32 mm material – a premiere for the city. The result was an amphitheatre and a new line of business for Dubi Hyams.

RM 70GO! 2.0

STRAIGHTFORWARD,
COMPACT AND POWERFUL

The RM 70GO! 2.0 is a flexible crusher with low emissions, low noise and low diesel consumption. It combines the highest possible mobility with easy handling - perfect for inner city job sites!



100 % emission-free with electric drive

TECHNICAL DATA

Throughput	up to 150 t/h, depending on material
Feed material size	up to an edge length of 600 mm
Feed opening	760 x 600 mm
Crusher unit	RM crusher with 2 or 4 hammers, 2 rotor speeds
Feed unit	asymmetric 2 m ³ vibro-channel with 2 vibration motors (3.1 kW each), loading height 2,660 mm, effective cross-section of feed intake: 2,500 x 1,800 mm Feed Control System for automatic load-dependent crusher feeding wear-resistant cladding Hardox 400
Main discharge belt (aggregate)	folding conveyor 800 mm wide, folds into transport position hydraulically discharge height 2,720 mm
Transport system	tracks
Weight	19,500 kg



JOB STORIES



STRICT EMISSIONS LAWS: RM 70GO! FULFILS ALL REGULATIONS

Clean Air Action Plan London against dust, exhaust and noise: RM has the solution for inner city building sites

The RM 70GO! 2.0 is one of the quietest crushers in the industry (80.6 db(A) at a distance of 10 metres) and has extremely low exhaust emissions. In just one step it processes C&D waste into perfect final aggregate. In just five days, the rented crusher turned 4,000 tonnes of C&D waste into material that could be used again immediately on a narrow inner city site near Camden Market.

GORONTALO: RM 70GO! 2.0 CRUSHES HARD RIVER BASALT

Effective and cost efficient: RM crusher replaces jaw and cone combination in Indonesia

The first RM crusher in Gorontalo has been in operation since 2017. The RM 70GO! 2.0 replaces two machines here: instead of the jaw and cone combination, it crushes extremely hard river basalt in a single pass (< =500mm to 0-63 mm). Main reasons for the purchase: the reliability of the machine the high quality final aggregate and the good relationship with the RM dealership.



“HIGH
QUALITY”

“RM convinced me with its high product quality, high throughput and compactness. Because it is so compact, the RM 70GO! is easy to manoeuvre and easy to feed. That's why you can use one of these crusher units with total flexibility on a variety of construction sites.”

Khun Chawachote Wangmontree, Managing Director, Sinsupanan Co., Ltd., Thailand

RM 90GO!

THE FLEXIBLE HIGH PERFORMANCE CRUSHER

This quiet, high performance crusher knows no compromises. With its compact size, even more flexibility and power under the hood, it delivers top performance for your success.

100 % emission-free with electric drive



“EXTREMELY POWERFUL”

“We got our first RM 90GO! one year ago. It is perfect for rental because RM crushers are unbelievably flexible, easy to use and extremely powerful. Even customers who have never worked with a crusher before can now easily recycle materials to save on disposal and protect the environment. In a few weeks, we will be taking delivery of our third.”

Paul Fot, company owner

TECHNICAL DATA

Throughput	up to 200 t/h, depending on material
Feed material size	up to an edge length of 650 mm
Feed opening	860 x 650 mm
Crusher unit	RM crusher with 2 or 4 hammers
Feed unit	asymmetric 2.6 m ³ vibro-channel with 2 vibration motors (3.1 kW each), loading height 2,880 mm, effective cross-section of feed intake: 2,980 x 1,990 mm Feed Control System for automatic load-dependent crusher feeding wear-resistant cladding Hardox 400
Main discharge belt (aggregate)	folding conveyor 800 mm wide, folds into transport position hydraulically discharge height 2,950 mm
Transport system	tracks
Weight	23,600 kg



JOB STORIES

HIGH QUALITY FINAL AGGREGATE FOR ROAD CONSTRUCTION IN SPAIN

Second crusher for loyal customer: with wind sifter for more possibilities, better final aggregate quality

After running an RM80 for a long time, the specialist in demolition, recycling and earthmoving ordered an RM 90GO! including infinitely variable hydraulic folding refeeding belt for oversized material and a wind sifter. The wind sifter blows lightweight material such as styrofoam and wood into a container for an even higher quality final aggregate (0.32 mm).



RM 90GO! CRUSHES GRANITE IN SKI AREA AT 2,650 M ABOVE SEA LEVEL

5,000 m³ in just four weeks to build a reservoir and road – efficient and environmentally friendly

In the ski arena at St. Moritz, the mobile RM 90GO! crushed granite for a challenging construction project (400 mm to 30-70 mm). Environmentally friendly on-site crushing saved innumerable journeys by truck. The customer was impressed with the top advice they received and the way the crusher manoeuvred its way along curving, narrow mountain roads.



RM 100GO!

EXTRA QUIET, EXTRA POWERFUL

The professional amongst the crushers will exceed your expectations: top productivity thanks to impressive power teamed up with easy operation and compact size.

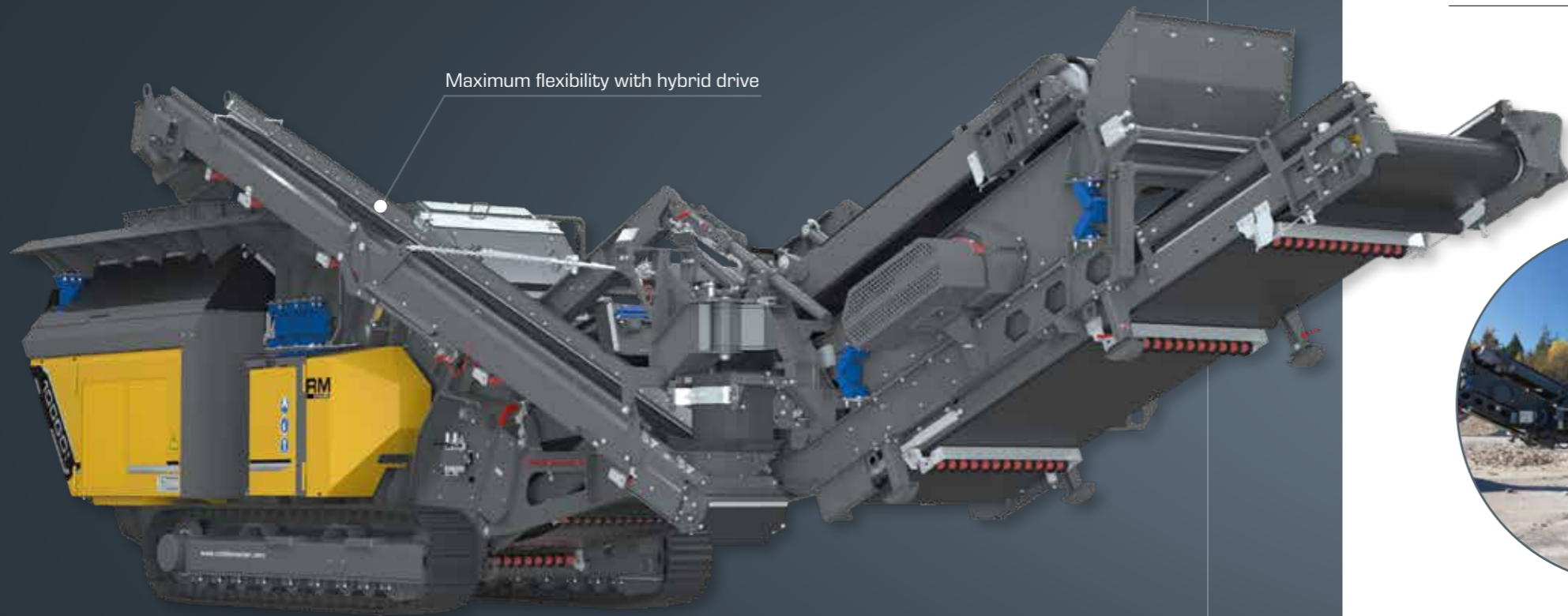

Maximum flexibility with hybrid drive

“PERFECTLY ENGINEERED”

“On RM crushers everything is very well engineered and thought-out, from simple hammer and screen changing to a multitude of crusher settings. The RM 100GO! is designed to do one thing very well – crush!”

Amanda Bright, CEO, Portland Road and Driveway, USA

TECHNICAL DATA

Throughput	up to 250 t/h, depending on material
Feed material size	up to an edge length of 750 mm
Feed opening	950 x 700 mm
Crusher unit	RM crusher with 2 or 4 hammers, 3 rotor speeds
Feed unit	asymmetric 3.3 m ³ vibro-channel with 2 vibration motors (3.1 kW each), loading height 3,000 mm, effective cross-section of feed intake: 2,980 x 2000 mm Feed Control System for automatic load-dependent crusher feeding wear-resistant cladding Hardox 400
Main discharge belt (aggregate)	folding conveyor 1,000 mm wide, folds into transport position hydraulically discharge height 3,350 mm
Transport system	tracks
Weight	29,000 kg



JOB STORIES

FAMILY FIRM GROWS WITH RM: SECOND CRUSHER NEEDED

Growth market recycling: RM 100GO! with wind sifter works flat out in southern Finland

Their RM 60 has been in operation successfully for many years, and now due to increased demand and a new environmental licence, they have added a new RM 100GO! to their fleet. The high performance crusher operates at the recycling depot and various job sites. The company, which specialises in demolition, mining and earthwork, is supported by RM dealership Hansa-Maschinen in Pori.



MEXICO: RM CRUSHER UNIT REPLACES JAW AND CONE COMBINATION

RM 100GO! crushes basalt for asphalt production: Increase in orders with cuboid final aggregate

The RM customer from Mexico prepares high-quality cuboid final aggregate of 0-19 and 0-25 mm at various sites. The requirements for asphalt production are high, and the quality and efficiency of the RM 100GO! are impressive. In addition, dispensing with one machine resulted in a considerable reduction in fuel, maintenance and transport costs.





TECHNISCHE DATEN

Throughput	up to 350 t/h, depending on material
Feed material size	up to an edge length of 850 mm
Feed opening	1.160 x 820 mm
Crusher unit	RM crusher with 2 or 4 hammers, 3 rotor speeds
Feed unit	asymmetric 4 m3 vibro-channel with 2 vibration motors (3.1 kW each), loading height 3,170 mm, effective cross-section of feed intake: 3.100 x 2.200 mm Feed Control System for automatic load-dependent crusher feeding wear-resistant cladding Hardox 450
Main discharge belt (aggregate)	1.200 mm wide, discharge height 3,600 mm
Transport system	tracks
Weight	35.600 - 46.400 kg

- Dust suppression system
- Magnetic separator
- Hammer changing device
- RM EXCLUSIVE Release System
- FULLY remote operated
- RM EXCLUSIVE Track and Crush
- Engine compartment lighting
- RM EXCLUSIVE Site Direct Training
- RM EXCLUSIVE Lifetime Support
- RM EXCLUSIVE 5 years warranty

➤ COST-EFFICIENT SOLUTION ◀



“Thanks to the new generation of RM hybrid crushers, the impact on our environment as well as the cost/tonne will continue to decrease. This allows us to offer our customers even more cost-efficient solutions.”

Julien Gagne
RME, France



The RM Group once again sets new standards in user-friendliness with RM NEXT. As the first NEXT philosophy crusher, the RM 120X combines enhanced safety with maximum performance and flexibility. Using RM Operations Assist and RM GO! SMART, the crusher interacts with the machine operator who is able to see the status of the machine from the loader cab. The performance indicator also enables maximum efficiency in processing without leaving the cab.



RM 120X

SIMPLY CLEVER

With its proven compactness and high throughput capacity, the RM flagship delivers enhanced safety and maximum flexibility. The interaction between the machine operator and the crusher enables maximum efficiency with maximum convenience.



1-2-3 GO!

EXTREMELY SIMPLE

Customers have been relying on the simplicity and user-friendliness of the RM GO! principle for many years. This is also an important part of RM NEXT. Despite these expansions, operating the machine remains as simple as usual.



EXTREMELY EFFICIENT

The optimal utilisation of RM machines combined with job-specific equipment options and real-time analysis optimises material throughput, reduces running costs and as a result increases turnover.



EXTREMELY SAFE

With the comprehensive operator-machine interface the operator no longer has to enter the danger zone while operating the machine and can see both the status and current utilisation of the crusher from the excavator cab.

RM V550GO!

REVOLUTIONARY TECHNOLOGY,
IDEAL FOR NATURAL ROCK

This machine combines the technologies of cone and impact crushers. Your fully mobile sand and grit plant delivers an extremely high grade of pulverisation and bypasses a crushing stage.

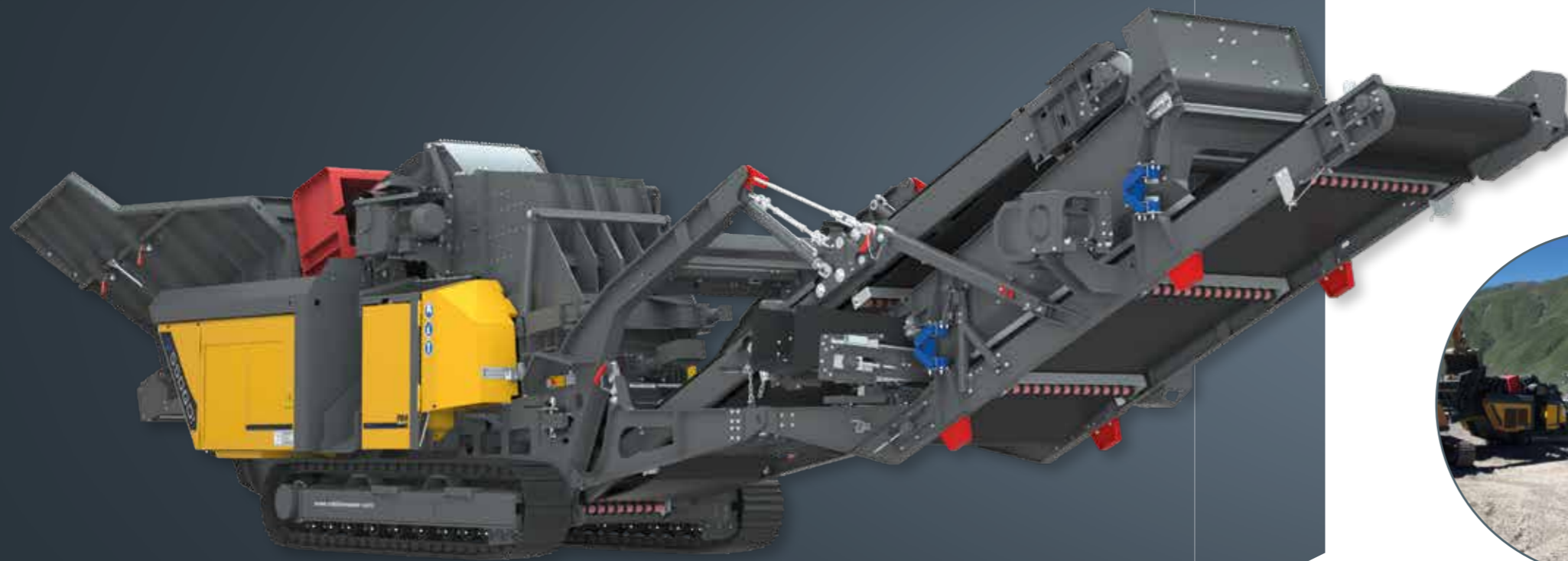

“OPTIMISED AND
EFFICIENT”

“The proportion of sand and the quality of the final aggregate are much higher with the RM V550GO! than with previous combinations. The 2nd and 3rd crushing stage have not just been replaced by the RM V550GO! but also optimised and made more efficient. The precisely cuboid material and the high proportion of sand are perfect for us!”

Juan Carlos Fischer, Company Owner,
El Camino, Paraguay

TECHNICAL DATA

Throughput	up to 200 t/h, depending on material
Feed material size	diagonal up to max. 300 mm
Feed opening	950 x 480 mm
Crusher unit	crusher with 2 or 4 hammers, rotor speed adjustable between 39.5 and 48 m/s, depending on feed material and required final aggregate
Feed unit	feed belt with 5.5 m ³ and 11 kW worm gear motor loading height 3,500 mm, effective cross-section of feed intake: 2,900 x 3,500 mm infinitely variable belt speed integrated metal detector to protect crusher against steel ingress
Main discharge belt	folding conveyor 1,000 mm wide, folds into transport position hydraulically discharge height 3,350 mm
Transport system	tracks, 2 crawler gear speeds
Weight	33,000 kg

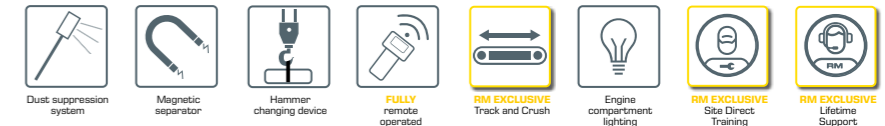

JOB STORY

RM V550GO! PROCESSES ROCK AT 2,000 METRES IN THE ANDES

**From a rock slide to ballast for the rail network:
tough raw material is turned into track ballast**

Heavy rainfall in Argentina's rainforests, which are traversed by mountain ranges, repeatedly leads to rock slides. The RM customer processes this quartzite rock with their RM V550GO! plus RM MSC8500M screen to produce 30-60 mm final aggregate. At the end of the project, the crusher is used for sand production. Thanks to its flexibility, it can be quickly adapted to take on new tasks.



RM MAKES THE DIFFERENCE



“FULL POTENTIAL”

with RM service ”

“We have been working with RM impact crushers for 15 years because they are so easy to operate and ready for use extremely quickly. Additionally, we know that we can rely on RM Lifetime Support at all times. Thanks to the RM 24/7 service, product training and active contact with our RM dealers we can tap into the full potential of the crusher.”

Ramón Fitó, Inhaber Excavacions I Transports Fitó, S.L., Spain



“IN SERVICE”

RM is the market leader ”

“RUBBLE MASTER is the market leader in service. It is not something that you can take for granted, that the wear parts you ordered the day before are then delivered the very next day. RM is a leader in all areas, in terms of quality and service.”

Hannes Kutzer, Construction Manager, Halbeisen & Prast KG, Austria



“EXCELLENT SERVICE”

“RM stands for excellent service and absolute reliability.”

Slendy Katalina Diaz Méndez, Geschäftsführerin, Construcción con Escombros SAS, Columbia



“WE ARE FAMILY”

“We have been business partners for 14 years. The continuous innovation at RM and their mobile crushers make us the market leader. We are committed to the partnership with our customers in the same way that we look after our partnership with RUBBLE MASTER. Innovation is the first key to success, being true partners in a business relationship is the second one in achieving our goal.”

Pascal Gosselin, Sales Manager at J. Y. Voghel Inc., Canada



SPEC2APP



ONE FOR EVERYBODY AND EVERYTHING

Everybody can operate the RM 120GO!. Straightforward, intuitive one-person operation eliminates complicated training. Changing application is no problem: the RM 120GO! is designed so that it can be quite simply upgraded and modified. The hammers can be replaced very quickly and the various linings and special accessories are added in no time. This makes compact crushing possible for the widest range of applications and materials – from processing recycling materials to natural rock.

YOUR ADVANTAGE

- Always the best solution for your requirements
- Always ready for action – even in difficult locations and in extreme conditions
- The highest flexibility, also for changing applications
- Excellent final aggregate quality in every application, supported by three different rotor speeds
- Always extremely easy to operate and service with optimum spare parts management

GO!

RM XSMART FLEET MANAGEMENT, CONDITION MONITORING AND APP ALL IN ONE



In terms of the construction site of the future, we are already doing everything we can to prepare RM XSMART for the future and to integrate further technologies as needed: Online remote control, fully networked machines and autonomous machines. With all your RM machines displayed on one dashboard, you can see all the key data for managing your fleet at a glance - anytime and anywhere.

» RM XSMART CONDITION MONITORING

Having machine data on hand is one of the prerequisites for invoicing customers in the rental business, and for verifying many legal regulations. Handwritten logbooks, laborious evaluation of machine data and phoning around to check operating hours used to be daily routine in the processing business. Enjoy the peace of mind of knowing that all your data is always at your fingertips. Even if the crusher is not connected to the network, the data is saved and uploaded later to ensure a reliable overview.

» RM XSMART APP

Until now, machine operators had to update handwritten logbooks as documentation. Evaluating machine performance had to be done from experience and, if an error occurred, the operator had to look up the error code in the manual, leave the excavator cab and check directly on the machine to see what the problem was. Get an overview of all the data you need to operate efficiently at all times, and get live throughput data from the conveyor scales on the discharge belts.

» RM XSMART FLEET MANAGEMENT

The daily work of rental fleet operators, workshop managers and machine owners is often to keep track of machines, schedule them in Excel lists and constantly coordinate the current machine status and availability. This takes a lot of time, and, because there is no central information point, it is difficult to keep everybody up-to-date. RM Fleet Management gives you more time for your projects.

» MORE TIME FOR YOUR PROJECTS

There is no money to be made from tedious searches for machine locations or time-consuming documentation. RM XSMART does this for you, leaving you more time to think ahead to the next projects.



RM XSMART
RUBBLEMASTER.COM



Welcome! to our world



RUBBLEMASTER.COM

RUBBLE MASTER HMH GmbH
Im Südpark 196, AT 4030 Linz, AUSTRIA
Tel: +43 732 - 73 71 17 - 0
Fax: +43 732 - 73 71 17 - 101
E-Mail: sales@rubblemaster.com
WEB: RUBBLEMASTER.COM

